



# Vehicle Services



Distributed by:



Ingersoll Rand Industrial Technologies provides products, services and solutions that enhance our customers' energy efficiency, productivity and operations. Our diverse and innovative products range from complete compressed air systems, tools and pumps to material and fluid handling systems. We also enhance productivity through solutions created by Club Car®, the global leader in golf and utility vehicles for businesses and individuals

1-800-866-5457 · [ingersollrandproducts.com](http://ingersollrandproducts.com)

© 2009 Ingersoll-Rand Company IRITS-0409-041 0611

[irtools.com](http://irtools.com)

If your tools aren't working,  
neither are you



For more than 100 years, professional technicians have relied on Ingersoll Rand for quality and performance on the toughest jobs. Our advanced engineering and manufacturing have set a standard of excellence often copied, but never matched. So, don't settle for less. Count on genuine Ingersoll Rand tools, accessories, and equipment.

### You can depend on Ingersoll Rand

- Best-in-class power and durability
- Improved ease of use
- Reduced downtime
- World-wide service network



#### United States

Ingersoll Rand  
Tel: +1-800-TOOLHLP  
Fax: +1-615-874-2523

#### Mexico

Ingersoll Rand S.A. de C.V.  
Tel: +52 55 5005-6600  
Fax: +52 55 5565-3072

#### Brazil

Ingersoll Rand do Brasil Ltda  
Tel: +55 11 2109-8900  
Fax: +55 11 2109-8998

#### Canada

Ingersoll Rand Canada  
Tel: +1-800-TOOLHLP  
Fax: +1-888-422-2258

#### Chile

Ingersoll Rand Chile  
Tel: +56 2 444-6800  
Fax: +56 2 485-8303

#### UK and Ireland

Ingersoll Rand Sales Co.  
Ltd.  
Tel: +44 1942 500030  
Fax: +44 1942 503451

#### Germany, Austria, and Switzerland

Ingersoll Rand GmbH  
Tel: +49 208 999 4422  
Fax: +49 208 999 4444

#### Belgium, Netherlands, and Luxembourg

Ingersoll Rand  
Tel: +33 8 10 22 27 77  
Fax: +33 1 30 07 69 80

#### Bulgaria, Romania, and Serbia and Montenegro

Ingersoll Rand  
Tel: +359 2 961 79 65  
Fax: +359 2 961 79 69

#### France

Ingersoll Rand  
Tel: +33 8 10 22 27 77  
Fax: +33 1 30 07 69 80

#### Scandinavia

Ingersoll Rand  
Tel: +47 2255 1526  
Fax: +47 2243 6581

#### Greece

Ingersoll Rand  
Tel: +33 1 30 07 69 60  
Fax: +33 1 30 07 69 80

#### Estonia, Latvia, and Lithuania

Ingersoll Rand  
Tel: +372 653 0110  
Fax: +372 653 0112

#### Spain and Portugal

Ingersoll Rand Iberica  
Tel: +34 91 6277405  
Fax: +34 91 6277406

#### Russia and CIS

Ingersoll Rand  
Tel: +7 495 933 03 24  
Fax: +7 495 785 21 26

#### Poland

Ingersoll Rand  
Tel: +48 22 635 72 45  
Fax: +48 22 635 73 32

#### Sub-Saharan Africa

Ingersoll Rand  
Tel: +27 11 864 3930  
Fax: +27 11 864 3954

#### Italy

Ingersoll Rand Italiana Spa  
Tel: +39 (0) 2 950561  
Fax: +39 (0) 2 95360159

#### Czech Republic and Slovakia

Ingersoll Rand  
Tel: +420 2 57 109 756  
Fax: +420 2 57 109 758

#### Hungary, Slovenia, and Croatia

Ingersoll Rand  
Tel: +36 28 512 800  
Fax: +44 1942 520319

#### Middle East and Northern Africa

Ingersoll Rand  
Tel: +971 (0) 43313984  
Fax: +971 (0) 43313032

#### Korea

Ingersoll Rand Korea  
Tel: +82-2-3660-6800  
Fax: +82-2-3141-8010

#### China

Shanghai Service Center  
Tel: +86-21-5691-1778  
Fax: +86-21-5691-1779

#### Malaysia

Ingersoll Rand Malaysia Co.  
Sdn.Bhd.  
Tel: +60-3-5633-3322  
Fax: +60-3-5634-5911

#### India

Ingersoll Rand Wadco Tools  
Pvt. Limited  
Tel: +91-120-4389200  
Fax: +91-120-4389444

#### Singapore

Ingersoll Rand South East Asia  
(Pte) Ltd.  
Tel: +65-6860-6800  
Fax: +65-6862-1373

#### Australia

Ingersoll Rand (Australia) Ltd.  
Tel: +61-3-8787-4300  
Fax: +61-3-8787-5510

#### Japan

Ingersoll Rand Japan, Ltd.  
Tel: +81-3-5420-3392  
Fax: +81-3-5420-9116





# HAMMERHEAD

LOW PROFILE IMPACTOOL™



# 2015 MAX

From Ingersoll Rand, the company that invented the Impactool in 1934, comes a revolutionary product that is unlike any other on the market today. The Hammerhead Low-Profile Impactool offers the power of an impact with the reach of a ratchet, and it's going to change the way you work. Say goodbye to awkward extensions and swivel sockets, and watch your productivity soar as you conquer tasks in minutes that once took you hours.

**"It's a knuckle saver... It gets into tight spots. You're not taking out half your tool box to get the job done... It' saves time."**

- Joe Illan  
Community Auto Repair  
Union, New Jersey

#### AWARD-WINNING INNOVATION



Come check out more customer testimonials on our youtube channel at:

[www.youtube.com/irtoolscom](http://www.youtube.com/irtoolscom)

**IR Ingersoll Rand**

# Contents



## Air Impacttools™ and Accessories ..... 6

Ingersoll Rand air Impacttools are the tools professional mechanics use when nothing else will do the job. They'll break loose a frozen bolt when others can't make it budge. With fewer working parts, simplified maintenance, and less wasted energy, Ingersoll Rand air Impacttools are the finest examples of delivering more power to professional mechanics.



## Air Ratchets and Accessories ..... 17

Compact. Convenient. Real time-savers. Air ratchets have become essential elements in every serious toolbox. Ingersoll Rand ratchets combine access and power to make jobs more productive and profitable, and feature unique qualities you won't find anywhere else.



## Sockets ..... 21

Backed by an extensive heritage of reliability and innovation, Ingersoll Rand introduces a comprehensive line of industrial-grade sockets that really make an impact.



## Air Grinders, Cutting Tools and Accessories ..... 28

With high-strength steels, advanced plastics, and new composite materials in today's cars and trucks, you need versatile tools for precise, controlled cutting. Ingersoll Rand cutting tools are the reliable choice of auto body and repair shops, used for everything from muffler and exhaust work to sunroof installations and body repairs.



## Air Finishing Tools and Accessories ..... 35

Ingersoll Rand has the most complete line of air finishing tools. Sanders, polishers, and buffers, from traditional styles for heavy material removal to the newest models for excellent control and brilliant surfaces. All Ingersoll Rand finishing tools are designed for long-life and swirl-free finishes.



## Air Drills, Screwdrivers, and Accessories ..... 41

Ingersoll Rand air drills have industrial-grade chucks and keyless chuck versions that are extra tough for drilling, sawing, valve guide reaming, cylinder honing, and wire brushing. They are powerful, efficient, and durable with smooth, quiet operation.



## Air Hammers and Accessories ..... 45

Our air hammers are designed so you can let the tool do the work, whether it's cutting, punching, chipping, or scraping. Each air hammer comes with a coil spring retainer for fast and easy chisel changes. You can also buy a five-piece chisel set, or get an Ingersoll Rand air hammer kit which includes both the hammer and the chisel set.

## Mini Air Tools and Accessories ..... 48

Ingersoll Rand offers a full line of mini air tools — 1/4" & 3/8" mini impacttool, mini random orbital sander, mini polisher, mini surface prep sander, and mini drill driver. All mini tools are also available in a kit.



## Cordless IQ<sup>V</sup>™ Tools and Accessories..... 52

Ingersoll Rand IQ<sup>V</sup> Series cordless tools are specifically designed for the service and production industries — delivering best-in-class power and durability, and a strong commitment to our customers. The same engineering that made our air tools the world's best now delivers cordless technologies that get the most out of every volt.



## Air Compressors and System Components ..... 65

For more than 75 years, Ingersoll Rand has been the world leader in air compressors and air system components. We understand rising energy costs and reduced margins require increased reliability and efficiency from not only your air compressor, but your entire air system. Simply stated, your air system is much more than an air compressor. It's the complete system — the piping, filters, dryers, drains, hoses, valves, and point-of-use tools.



## Lubrication Equipment and Accessories ..... 80

Ingersoll Rand lubrication equipment reflects the same high standards of performance as our tools and air compressors, with a full range of products that will keep all types of fluids moving efficiently. These products are the result of more than 70 years of experience in pump and air system technology, and include models specifically designed for popular applications.

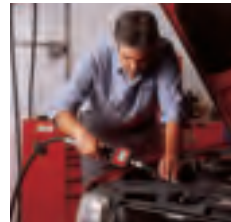

## Accessories ..... 92

We offer an extensive line of accessories to match our tools with the requirements of every job. These accessories put the reliability and quality of Ingersoll Rand behind every job you do.



## Pullers and Hoists ..... 103

Ingersoll Rand pullers and hoists are designed to handle tough pulling or lifting jobs with minimal effort by the operator. Whether it's a low-, medium-, or heavy-duty job, you can trust our pullers and hoists to carry the load safely and easily.

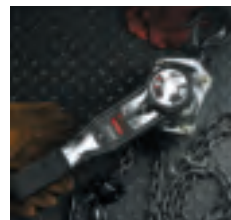

See page 108 for complete Index

# Air Impacttools™



There are good reasons why Ingersoll Rand pneumatic Impacttools are so highly regarded by professionals, especially in the automotive service industry. With decades of proven engineering expertise behind them, our Impacttools deliver rugged reliability and power in durable, compact packages. Ingersoll Rand pneumatic Impacttools offer the best power-to-weight ratios available on the market.



Model	Max Torque ft-lb (Nm)	Working Torque Range ft-lb (Nm)	Free Speed rpm	Weight lb (kg)	Length in (mm)	Average Air Consumption cfm (L/min)	Air Consumption @ Load cfm (L/min)	Sound Pressure / Power dBA	Air Inlet NPTF in	Min Hose Size in (mm)
<b>1/4" MINI IMPACTTOOL</b>										
2101XP	50 (68)	25 – 40 (34 – 54)	11,000	1.4 (0.6)	6.3" (160)	1.8 (50)	18.2 (516)	81.8 / 92.8	1/4"	3/8" (10)
2101XP-QC*	50 (68)	25 – 40 (34 – 54)	11,000	1.4 (0.6)	6.8" (173)	1.8 (50)	18.2 (516)	81.8 / 92.8	1/4"	3/8" (10)
<b>3/8" MINI IMPACTTOOL</b>										
2102XP*	50 (68)	25 – 40 (34 – 54)	11,000	1.4 (0.6)	6.3" (160)	1.8 (50)	18.2 (516)	81.8 / 92.8	1/4"	3/8" (10)
<b>3/8" SQUARE DRIVE</b>										
211*	150 (204)	20 – 125 (27 – 170)	10,000	2.40 (1.09)	6.6" (168)	2.5 (71)	11 (311)	104 / 117	1/4"	3/8" (10)
<b>216B</b>	<b>200 (271)</b>	<b>15 – 160 (20 – 217)</b>	<b>8,500</b>	<b>2.8 (1.27)</b>	<b>7.7 (196)</b>	<b>3 (85)</b>	<b>19 (538)</b>	<b>94.8/105.8</b>	<b>¼ (6)</b>	<b>3/8 (10)</b>
212*	150 (205)	20 – 125 (27 – 170)	11,500	2.89 (1.31)	6" (152)	2.5 (71)	11 (311)	97 / 108	1/4"	3/8" (10)
<b>2015MAX</b>	<b>180 (244)</b>	<b>45 – 160 (61 – 217)</b>	<b>9,000</b>	<b>3.4 (1.54)</b>	<b>13.1 (332)</b>	<b>3.5 (99)</b>	<b>19 (538)</b>	<b>96.6/107.6</b>	<b>1/4"</b>	<b>3/8" (10)</b>
2115QTiMAX*	300 (407)	25 – 230 (34 – 312)	15,000	2.49 (1.13)	5.95" (151)	4 (113)	17 (481)	89.7 / 100.7	1/4"	3/8" (10)
2115TiMAX	300 (407)	25 – 230 (34 – 312)	15,000	2.48 (1.12)	5.95" (151)	4 (113)	17 (481)	96.6 / 107.6	1/4"	3/8" (10)

\*Not pictured.

## 2101XP

### 1/4" Mini Impactool

Whether you're working in tight spaces or doing finely detailed finish work, our mini tools deliver the power, versatility, and durability you want, in a conveniently smaller size

- Hard-hitting 5-vane motor delivers smooth and robust performance
- Easily accessible forward / reverse switch for one-handed operation



Fastens conveniently in hard-to-reach places

## 2101K

### 1/4" Mini Impactool Kit

- Includes 10-piece 1/4" socket set

## 2015MAX

### Air Impactool

This revolutionary product is unlike any other on the market today. The Hammerhead Low Profile Impactool offers the power and speed of an impact with the reach of a ratchet. The combination of MAX power, MAX control, and MAX access now allows you to use an Ingersoll Rand Impactool for virtually any application. Say goodbye to awkward extensions and swivel sockets, and watch your productivity soar as you conquer tasks in minutes that once took you hours.

#### MAX Power

With 180 ft-lb max torque and 7,100 rpm, Hammerhead offers more than twice the power of the leading competitor's ratchet.

#### MAX Control

A feather-touch trigger, two-position forward power regulator, and conveniently located forward/reverse ring provide precise control.

#### MAX Access

A head height of under 2" and reactionless torque allow you to safely use this powerful tool in tight spaces.



## 216B

### In-line Air Impactool

This durable in-line wrench is handy for the cramped spaces common to small engine repair and other general service work. The butterfly-style throttle valve lets you adjust speed smoothly in either direction in one continuous motion.

- 175 ft-lb max torque
- Contoured composite butterfly throttle for comfort and control
- Recessed regulator dial



## 2115TiMAX

### Air Impactool

The new 2115TiMAX delivers best in class performance for a tool less than six inches long and weighing less than two and a half pounds. The minimal size of this tool will allow greater access to tight spaces, while the minimal weight will reduce operator fatigue all while still delivering MAX performance.

#### MAX Power

300 ft-lbs max power in reverse – that's best in class power performance

#### MAX Control

Enhanced power settings, a feather touch trigger and patented push button forward/reverse provide maximum control

#### MAX Reliability

FREE two-year limited warranty with tool registration



Best power-to-weight ratio in its class

## 1/2" Impacttools

Model	Max Torque ft-lb (Nm)	Working Torque Range ft-lb (Nm)	Free Speed rpm	Weight lb (kg)	Length in (mm)	Average Air Consumption cfm (L/min)	Air Consumption @ Load cfm (L/min)	Sound Pressure / Power dBA	Air Inlet NPTF in	Min Hose Size in (mm)
<b>1/2" SQUARE DRIVE</b>										
231C	600 (813)**	25 – 350 (34 – 475)	8,000	5.8 (2.63)	7.3" (185)	4.2 (119)	22 (623)	99 / 110	1/4"	3/8" (10)
236*	450 (610)	25 – 200 (34 – 271)	7,400	5.3 (2.4)	7.1" (180.3)	4.3 (122)	24 (680)	90.3 / 101.3	1/4"	3/8" (10)
244A	500 (678)	40 – 350 (54 – 475)	7,000	6 (2.72)	7.3" (185)	5.4 (153)	21 (595)	93 / 104	1/4"	3/8" (10)
244A-2*	500 (678)	40 – 350 (54 – 475)	7,000	6.3 (2.85)	9.5" (241)	5.4 (153)	21 (595)	93 / 104	1/4"	3/8" (10)
231HA*	590 (800)**	25 – 350 (34 – 475)	8,000	5.8 (2.63)	7.3" (185)	4.2 (119)	22 (623)	94 / 105	1/4"	3/8" (10)
231HA-2	590 (800)**	25 – 350 (34 – 475)	8,000	6.1 (2.76)	9.1" (236)	4.2 (119)	22 (623)	94 / 105	1/4"	3/8" (10)

\*Not pictured.

\*\*Reverse bias.

### 231C

#### Air Impactool

The classic 231C is the most popular tool in its class. Introduced over 25 years ago and continuously refined, it offers the sheer power and performance features to tackle the toughest jobs with ease — as well as proven durability and economy.

- Adjustable power regulator
- Pressure-fed lubrication
- Easy-to-service 2-piece construction



**The most popular  
Impactool in the world**

### 244A

#### Air Impactool

Bring out the "big gun" for tire-changing, shock and spring work, front-end work, and other heavy automotive and truck work. The impact mechanism pumps out 500 ft-lb of torque at a free speed of 7,000 rpm to get the job done fast.

- Powerful with smooth, balanced blows
- Pressure-fed lubrication system automatically greases the impact mechanism
- Non-biased 500 ft-lb in forward and reverse



### 231HA-2

#### Extended Anvil Air Impactool

The 231HA-2 has set the standard for Impactool performance for over three decades. Refined engineering and design have perfected performance and made the 231HA-2 one of the most popular tire service Impactools ever. This elite mechanism is the perfect balance between superior power and proven durability.

- Pressure-fed lubrication system
- Handle exhaust directs air away from user
- Adjustable power regulation

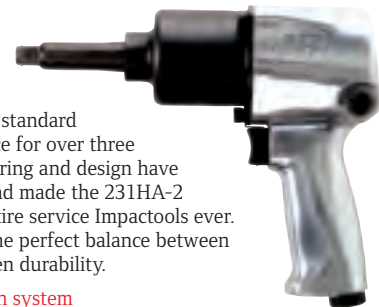

**Top choice in tire  
service centers**

## Sockets

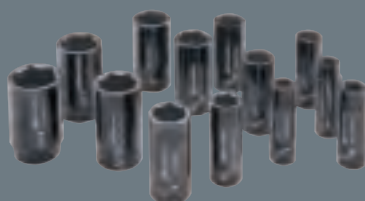

Genuine Ingersoll Rand Impact sockets are built with top-quality materials for performance and durability. For more information, turn to the sockets section — starting on page 21. See pages 14 – 16 for all other Impactool accessories.



Model	Max Torque ft-lb (Nm)	Working Torque Range ft-lb (Nm)	Free Speed rpm	Weight lb (kg)	Length in (mm)	Average Air Consumption cfm (L/min)	Air Consumption @ Load cfm (L/min)	Sound Pressure / Power dBA	Air Inlet NPTF in	Min Hose Size in (mm)
<b>1/2" SQUARE DRIVE</b>										
2025MAX*	180 (244)	45-160 (61-217)	9,000	3.4 (1.54)	13.1 (332)	3.5 (99)	19 (538)	96.6/107.6	1/4"	3/8" (10)
2125QTiMAX*	332 (450)**	25 - 251 (34 - 340)	15,000	2.51 (1.14)	6.1" (155)	4 (113)	17 (481)	89.7 / 100.7	1/4"	3/8" (10)
2130	550 (745)**	50 - 500 (68 - 680)	9,500	4.2 (1.9)	7.25" (184)	4.4 (124.6)	22 (623)	96.6 / 109.6	1/4"	3/8" (10)
2130-2*	550 (745)**	50 - 500 (68 - 680)	9,500	4.6 (2.05)	9.25" (235)	4.4 (124.6)	22 (623)	96.6 / 109.6	1/4"	3/8" (10)
232TGSL	625 (847)**	40 - 400 (54 - 544)	10,000	6 (2.72)	7.3" (185)	5.4 (153)	23 (651)	105 / 109.3	1/4"	3/8" (10)

\*Not pictured.  
\*\*Reverse bias.

## 2130

### Air Impactool

The 2130 has all the performance features you have come to expect from the Ingersoll Rand family of Impacttools. This Impactool features a powerful twin-hammer mechanism and a composite housing, providing superior ergonomics in a lightweight package.

- 550 ft-lb maximum torque
- Full-stroke tease throttle
- Multi-position power management



Ingersoll Rand power and durability at an exceptional value

## 232TGSL

### ThunderGun® Street Legal™ Air Impactool

As close as you can get to the real racing tools used by 100 percent of NASCAR® pit crews. It features 625 ft-lb of torque in reverse, with 10,000 rpm to deliver pit crew power, speed, and durability.

- Our fastest 1/2" Impactool
- 10,000 rpm for lightning fast removal is best-in-class
- 625 ft-lb of torque



## Impact Boots



Even the industry's hardest-working Impacttools could use added protection from the rigors of the jobsite. Our impact boots can be found on page 16. For a complete listing of Impacttool accessories, see pages 14 - 16.

## 1/2" Impacttools

Model	Drive in	Max Torque (reverse) ft-lb (Nm)	Nut Busting Torque ft-lb (Nm)	Forward Torque Range ft-lb (Nm)	Blows per minute	Free Speed rpm	Sound Pressure / Power dBA	Net Weight lb (kg)	Overall Length in (mm)	Average Air Consumption cfm (L/min)	Air Inlet NPTF in	Min Hose Size in (mm)
<b>1/2" SQUARE DRIVE</b>												
2135TiMAX	1/2"	780 (1054)	1,100 (1486)	50 – 550 (68 – 746)	1,250	9,800	109	3.95 (1.79)	7.35 (186.7)	5 (142)	1/4"	3/8" (10)
2135Ti-2MAX*	1/2"	780 (1054)	1,100 (1486)	50 – 550 (68 – 746)	1,250	9,800	109	4.4 (1.99)	9.47 (240.5)	5 (142)	1/4"	3/8" (10)
2135QTiMAX*	1/2"	780 (1054)	1,100 (1486)	50 – 550 (68 – 746)	1,250	9,800	86	4.05 (1.83)	7.35 (186.7)	5 (142)	1/4"	3/8" (10)
2135QTi-2MAX*	1/2"	780 (1054)	1,100 (1486)	50 – 550 (68 – 746)	1,250	9,800	86	4.5 (2.04)	9.47 (240.5)	5 (142)	1/4"	3/8" (10)

\*Not pictured.  
\*\*Reverse bias.

### 2135TiMAX

#### Air Impact Wrench

The Titanium 2135TiMAX delivers 1,100 ft-lb of nut-busting torque in a gun that weighs just 3.95 lb. The 7-vane power plant drives enough torque to break away a nut tightened to over 1,100 ft-lb in under six seconds.

#### MAX Power

780 ft-lb maximum reverse torque from a tool weighing less than 4 lb. — that's the best power-to-weight ratio in its class

#### MAX Control

Feather-touch trigger, wider range of power regulator settings in forward, always max power in reverse, patented one-hand forward / reverse control

#### MAX Reliability

Free two-year limited warranty with tool registration



The best power-to-weight ratio in its class



### Quiet Tools

All the power, without all the noise.

At Ingersoll Rand, we don't just stand behind our tools; we're equally devoted to the people who use them. We're constantly looking for ways to make your job easier.

With the innovative line of Quiet Tools from Ingersoll Rand, you get durable, reliable tools that deliver the power you need, but with less noise. Our patented Quiet Tool technology reduces the sound levels caused by air pulsating through the impact motor, without compromising our best-in-class torque levels.

Power and performance with less noise? Sure sounds good to us.

Models: 2115QTiMAX, 2125QTiMAX, 2135QTiMAX, 2135QTi-2MAX

## Impactool Tune-up Kits



Extend the life of your tools. Even the most durable and reliable tools need preventive maintenance. Our Impactool tune-up kits and full line of Impactool accessories can be found on pages 14 – 16.

## 3/4" Impacttools

Model	Max Torque ft-lb (Nm)	Working Torque Range ft-lb (Nm)	Free Speed rpm	Weight lb (kg)	Length in (mm)	Average Air Consumption cfm (L/min)	Air Consumption @ Load cfm (L/min)	Sound Pressure / Power dBA	Air Inlet NPTF in	Min Hose Size in (mm)
<b>3/4" SQUARE DRIVE</b>										
259	1050 (1424)	200 – 800 (271 – 1085)	6,000	8.8 (4.0)	8.6 (218)	8 (227)	30 (850)	91.6/102.6	3/8"	3/8 (10)
261	1,100 (1491)	200 – 900 (272 – 1224)	5,500	12.4 (5.62)	8.8" (224)	9.5 (269)	38 (1076)	98.1 / 109.1	3/8"	1/2" (13)
261-3*	1,100 (1491)	200 – 900 (272 – 1224)	5,500	13 (5.9)	11.8" (300)	9.5 (269)	38 (1076)	98.1 / 109.1	3/8"	1/2" (13)
261-6*	1,100 (1491)	200 – 900 (272 – 1224)	5,500	13.7 (6.21)	14.8" (376)	9.5 (269)	38 (1076)	98.1 / 109.1	3/8"	1/2" (13)
2141	1,200 (1627)	200 – 900 (272 – 1224)	8,000	7 (3.2)	8.2" (208)	9.5 (269)	40 (1133)	99.9 / 110.9	3/8"	1/2" (13)
2161XP	1,250 (1695)	300 – 1,000 (459 – 1654)	6,000	11.8 (5.35)	8.5" (216)	10 (283)	46 (1303)	98 / 111	3/8"	1/2" (13)
2161XP-6*	1,250 (1695)	300 – 1,000 (459 – 1654)	6,000	13.1 (5.95)	14.5" (368)	10 (283)	46 (1303)	98 / 111	3/8"	1/2" (13)

\*Not pictured.

### 261

#### Air Impactool

The highly regarded 261 model combines compact size at only 8.8" long with high output, which makes it perfect for everything from spring work to pinion nut and track pad removal and major engine teardowns.

- Jumbo hammer mechanism
- Up to 1,100 ft-lb of torque
- Pressure-fed lube system for trouble-free performance and longer life

For optional power regulator, please order part #2920-K329.



### 259

#### Air Impactool

The new 259 3/4" Impactool™ delivers the power, durability, reliability, and value to get the job done right. It offers impressive performance, value, and convenience not found in competitive models.

- Smaller and up to 2 pounds (.91 kg) lighter than other 3/4" impacts in its class
- Rocking dog impact mechanism works well on a wide range of air pressures
- Silenced exhaust reduces tool noise while in use



### 2141

#### Air Impactool

The 2141 delivers the best power-to-weight ratio and best size ratio in its class. The 2141 also provides great maneuverability for tight, awkward spaces.

- 1,200 ft-lb maximum torque
- Weighs just 7 lb
- Contoured professional touch trigger and ergonomically designed handle for increased comfort



The best power-to-weight ratio in its class

### 2161XP

#### Air Impactool

The 2161XP combines a 6-vane, high-output air motor, through-bolt construction, ergonomic handle and housing design to create an Impactool that offers increased power and durability.

- Most powerful 3/4" Impactool in the industry
- Maximum torque of 1,250 ft-lb
- 3-position power regulator and 360° swivel inlet



## 1" Impacttools

Model	Max Torque ft-lb (Nm)	Working Torque Range ft-lb (Nm)	Free Speed rpm	Weight lb (kg)	Length in (mm)	Average Air Consumption cfm (L/min)	Air Consumption @ Load cfm (L/min)	Sound Pressure / Power dBA	Air Inlet NPTF in	Min Hose Size in (mm)
<b>1" SQUARE DRIVE</b>										
271	1,100 (1491)	200 – 900 (272 – 1224)	5,500	12.5 (5.67)	8.9" (226)	9.5 (269)	39 (1104)	98.1 / 109.1	3/8"	1/2" (13)
285B*	1,475 (2000)	100 – 900 (136 – 1220)	5,000	24.6 (11.16)	13.2" (335)	10 (283)	37 (1048)	103.4 / 114.4	1/2"	1/2" (13)
285B-6	1,475 (2000)	100 – 900 (136 – 1220)	5,000	27.8 (12.61)	20.1" (511)	10 (283)	37 (1048)	103.4 / 114.4	1/2"	1/2" (13)
280*		1,600 (2169)	150 – 1,000 (204 – 1360)		6,000	22 (9.98)	13" (330)	10 (283)	55 (1557)	109.1 / 122.1
122.11/2"	1/2" (13)									
280-6	1,600 (2169)	150 – 1,000 (204 – 1360)	6,000	23.8 (10.80)	18.5" (470)	10 (283)	55 (1557)	109.1 / 122.1	1/2"	1/2" (13)
<b>#5 SPLINE DRIVE</b>										
285B-S6*	1,475 (2000)	100 – 900 (136 – 1220)	5,000	27.8 (12.61)	20.1" (511)	10 (283)	37 (1048)	103.4 / 114.4	1/2"	1/2" (13)
280-S-6*	1,600 (2169)	150 – 1,000 (204 – 1360)	6,000	23.8 (10.80)	18.5" (470)	10 (283)	55 (1557)	109.1 / 122.1	1/2"	1/2" (13)

### 271

#### Air Impactool

The shortest 1" air Impactool is also one of the most powerful. It combines a compact size with high power output, making it ideal for tire changing, spring work, pinion nut removal, tractor pad removal, and shock work.

- Impressive power-to-size ratio
- Up to 1,100 ft-lb of torque
- Pressure-fed lube system for longer service life



### 280-6

#### Air Impactool

High-production truck tire changing requires the brute force only this jumbo hammer impact mechanism delivers. Reach into deep truck wheels easily with this 6" extended anvil wrench, designed for high-production truck tire changing.

- 1,600 ft-lb of maximum torque
- Jumbo power mechanism for power and durability
- In-handle exhaust directs air away from user



### 285B-6

#### Air Impactool

The 285B models combine exceptional power, control and durability. They deliver 1,770 ft-lb of maximum torque @ 120 psi, with 5,250 rpm free speed and a high-efficiency, 6-vane motor. The swept-back 285B handle provides excellent maneuverability.

- Delivers 1,475 ft-lb maximum torque
- Fast-torque™ delivers 1,000 ft-lb in 2 seconds
- Improved feather touch trigger

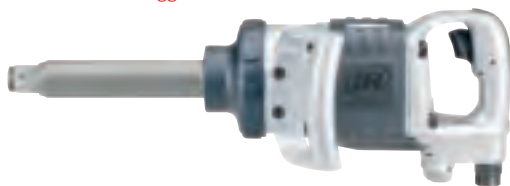

Enhanced durability  
for longer life



Model	Max Torque ft-lb (Nm)	Working Torque Range ft-lb (Nm)	Free Speed rpm	Weight lb (kg)	Length in (mm)	Average Air Consumption cfm (L/min)	Air Consumption @ Load cfm (L/min)	Sound Pressure / Power dBA	Air Inlet NPTF in	Min Hose Size in (mm)
<b>1" SQUARE DRIVE</b>										
2171XP	1,250 (1695)	300 – 1000 (459 – 1654)	6,000	13.1 (5.95)	12.5" (318)	10 (282)	46 (1303)	98 / 111	3/8"	1/2" (13)
295A	1,475 (2000)	100 – 900 (136 – 1220)	5,000	22.3 (10.12)	10.5" (267)	10 (283)	45 (1274)	101.1 / 112.1	1/2"	1/2" (13)
290	1,600 (2169)	150 – 1,000 (203 – 1356)	6,000	21.9 (9.93)	9.75" (248)	10 (283)	60 (1699)	104.6 / 117.6	1/2"	3/4" (19)
2190Ti*	1,650 (2237)	150 – 1,000 (203 – 1627)	6,800	14 (6.4)	15.38" (391)	12 (336)	58 (1642)	103.8 / 116.8	1/2"	1/2" (13)
2190Ti-6	1,650 (2237)	150 – 1,000 (203 – 1627)	6,800	15.5 (7.03)	21.48" (546)	12 (336)	58 (1642)	103.8 / 116.8	1/2"	1/2" (13)
2190DTi-6*	1,650 (2237)	150 – 1,000 (203 – 1627)	6,800	16 (7.3)	21.48" (546)	12 (336)	58 (1642)	103.8 / 116.8	3/8"	1/2" (13)
293*	2,000 (2712)	1,000 – 1,600 (1360 – 2176)	3,500	22.8 (10.34)	11.3" (287)	12 (340)	64 (1812)	90.3 / 103.3	1/2"	3/4" (19)
<b>#5 SPLINE DRIVE</b>										
290-S*	1,600 (2169)	150 – 1,000 (203 – 1356)	6,000	21.9 (9.93)	10" (254)	10 (283)	60 (1699)	104.6 / 117.6	1/2"	3/4" (19)
293-S*	2,000 (2712)	1,000 – 1,600 (1360 – 2176)	3,500	22.8 (10.34)	11.3" (287)	12 (340)	64 (1812)	90.3 / 103.3	1/2"	3/4" (19)

\*Not pictured.

## 2171XP

### Air Impactool

The 2171XP combines a 6-vane high output air motor, through-bolt construction, ergonomic handle and housing design to create an Impactool that offers increased power and durability.

- Maximum torque of 1,250 ft-lb
- 3-position power regulator
- 360° swivel inlet



## 290

### Air Impactool

Designed for getting into cramped spaces with big power, the 290 has a 3-way adjustable handle. It's a good choice for spring work, tractor pads, bus maintenance, off-road equipment, and farm equipment.

- Up to 1,600 ft-lb of torque

For optional thread-on muffler, order part #2910-674.



## 2190Ti-6

### Air Impactool

Designed specifically for high-volume fleet service, the revolutionary chainsaw-grip handle provides comfortable control to the operator. The 2190Ti-6 delivers an impressive 1,650 ft-lb of maximum torque in a lightweight package and comes standard with a 6" extended anvil.

- 1,650 ft-lb of maximum torque
- Weighs 15.5 lb
- Extended robust anvil bushing provides long life under heavy shop usage



## 295A

### Air Impactool

The 295A model combines exceptional power, control, and durability. It delivers 1,770 ft-lb of maximum torque @ 120 psi (1,475 ft-lb @ 90 psi), with 5,250 rpm free speed and a high-efficiency, 6-vane motor. The top-mounted 295A dead handle provides great leverage for difficult underbody work.

- Delivers 1,770 ft-lb maximum torque
- Fast-torque™ delivers 1,000 ft-lb in 2 seconds
- Improved feather touch trigger
- Rubber boots protect tools from exterior damage

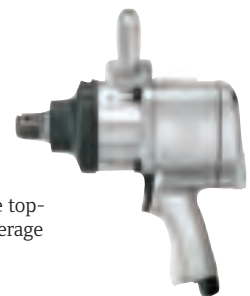

## Impactool Hammer Kit



See pages 14 – 16 for our full line of Impactool accessories.

## Impactool Tune-up Kits

Extend the life of your tools with genuine Ingersoll Rand repair kits and replacement parts. Every Ingersoll Rand part is specifically designed to enhance durability and improve the productivity of your tool.

Part Number	For Use With
<b>3/8" IMPACTOOL TUNE-UP KITS</b>	
2015-TK	2015MAX
211-TK2	211
212-TK2	212
2115-TK2	2115TiMAX Series
<b>1/2" IMPACTOOL TUNE-UP KITS</b>	
2015-TK	2025MAX
2130-TK1	2130, 2130-2
2135-TK2	2135 Series, 2135TiMAX Series
236-TK1	236
231HP-TK1	231HA, 231HA-2
231-TK2	2141
231-TK3	231C
244-TK2	244A, 244A-2

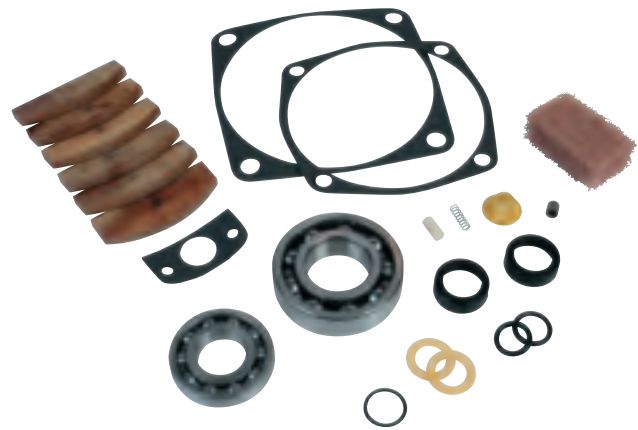

Part Number	For Use With
<b>3/4" IMPACTOOL TUNE-UP KITS</b>	
259-TK1	259
261-TK2	261, 261-3, 261-6, 271
2141-TK1	2141
2161-TK2	2161XP, 2161XP-6
<b>1" IMPACTOOL TUNE-UP KITS</b>	
280-TK2	280, 280-6, 280-S6
285B-TK1	285B, 285B-6, 285B-S6
295A-TK1	295A
2190-TK1	2190Ti, 2190DTi-6, 2190Ti-6
290-TK2	290

## Impactool Hammer and Anvil Kits

Part Number	For Use With
<b>3/8" IMPACTOOL HAMMER AND ANVIL KITS</b>	
2112-THK1	2112
2115-THK2	2115TiMAX Series
<b>1/2" IMPACTOOL HAMMER AND ANVIL KITS</b>	
2135-THK1	2135TiMAX, 2135QTiMAX
2135-2-THK1	2135Ti-2MAX, 2135QTi-2MAX
231B-THK1	231C, 231HA, 244A
231B-THK2	231HA-2, 244A-2
231C-THK1	231C
<b>3/4" IMPACTOOL HAMMER AND ANVIL KITS</b>	
261-THK1	261
2141-THK1	2141
<b>1" IMPACTOOL HAMMER AND ANVIL KITS</b>	
2190-THK1	2190Ti
285A-6-THK1	285B
2190-6-THK1	2190Ti-6, 2190DTi-6



If your tools aren't working, neither are you! Protect your tools with genuine Ingersoll Rand parts and services.

## Air Tool Lubricants

Regular tool lubrication will keep your tool running at peak performance for a longer time. Our full line of air tool lubricants can be found on page 96.

## Ergonomic Accessories

Ingersoll Rand offers a handy line of ergonomic accessories that enable you to work more safely and more comfortably. Our tool boots absorb vibrations and protect the tool from external damage. Ingersoll Rand comfort grips protect you from mechanical shocks and tool vibration, and our braces allow for more consistent torque output and eliminate the need for a dead handle.

### Protective Tool Boots

Part Number	Description	For Use With
<b>PROTECTIVE TOOL BOOTS</b>		
212-BOOT	Impactool boot with Ingersoll Rand logo printed on red boot	212
2115M-BOOT	Premium Impactool boot with Ingersoll Rand logo	2115TiMAX Series
2130-BOOT	Premium Impactool boot with Ingersoll Rand logo	2130, 2130-2
2135M-BOOT	Premium Impactool boot with Ingersoll Rand logo	2135TiMAX, 2135Ti-2MAX, 2135QTiMAX, 2135QTi-2MAX, 2135QPTiMAX
2015-BOOT	Premium Impactool boot with Ingersoll Rand logo	2015MAX, 2025MAX
2141-BOOT	Premium Impactool boot with Ingersoll Rand logo	2141
259-BOOT	Premium Impactool boot with Ingersoll Rand logo	259
2161-BOOT	Impactool boot with Ingersoll Rand logo printed on red boot	2161XP, 2161XP-6
2190-BOOT	Premium Impactool boot with Ingersoll Rand logo	2190Ti, 2190Ti-6

- Specifically designed for use with our air Impactools
- Keep your tools clean and protected from external damage



212-BOOT



2135M-BOOT



2015-BOOT



232TGSL-P32

Part Number	Description	For Use With
<b>PROTECTIVE TOOL BOOTS</b>		
236-BOOT	Impactool boot with Ingersoll Rand logo printed on red boot	236
244-BOOT	Impactool boot with Ingersoll Rand logo printed on red boot	244A, 244A-2
261-BOOT	Impactool boot with Ingersoll Rand logo printed on red boot	261, 261-3, 261-6
285-BOOT	Impactool boot with Ingersoll Rand logo printed on red boot	285B, 285B-6
295-BOOT	Impactool boot with Ingersoll Rand logo printed on red boot	295, 295-S
231-BOOT	Impactool boot with Ingersoll Rand logo printed on red boot	231C, 231HA, 231HA-2
232TGSL-P32	ThunderGun Street Legal Impactool boot	232TGSL

### 285B Replacement Boots

Part Number	Description	For Use With
<b>PROTECTIVE TOOL BOOTS</b>		
431L-62	Rubber hammer case guard	285B, 285B-6, 285B-S6
431L-32	Rubber motor housing guard	285B, 285B-6, 285B-S6



431L-62



431L-32

### Light Holder Boots

Part Number	Description	For Use With
2115M-BOOT-LED	Premium boot with LED flashlight holder (kit includes LED flashlight)	2115TiMAX Series
231-BOOT-LED	Premium boot with LED flashlight holder (kit includes LED flashlight)	231
2135M-BOOT-LED	Premium boot with LED flashlight holder (kit includes LED flashlight)	2135TiMAX Series



2115M-BOOT-LED



231-BOOT-LED



2135M-BOOT-LED



# Air Ratchets



For more than 100 years, Ingersoll Rand has been designing world-class tools of the highest quality, durability, and reliability. This legacy of excellence and performance is evident in our line of pneumatic ratchets. Smaller in size and more powerful than competitive models, our ratchets are specifically engineered to make your job easier and you more productive. Our ratchets are also very convenient to use, thanks to enhanced ergonomics.



## Air Ratchets

Model	Square Drive	Max Torque ft-lb (Nm)	Free Speed rpm	Weight lb (kg)	Length in (mm)	Average Air Consumption cfm (L/min)	Average Air Consumption @ Load cfm (L/min)	Sound Pressure / Power dBA	Air Inlet NPTF in	Min Hose Size in (mm)
<b>1/4" SQUARE DRIVE</b>										
105-D2	1/4"	25 (34)	250	1.4 (0.64)	7.3 (186)	3 (85)	18 (510)	81.8/92.8	1/4"	3/8"
105-L2	1/4"	25 (34)	250	1.56 (0.71)	8.41 (214)	3 (85)	18 (510)	81.6/92.6	1/4"	3/8"
1105MAX-D2	1/4"	30 (41)	300	1.43 (0.65)	7.36 (187)	3.5 (99)	20 (566)	88.9/99.9	1/4"	3/8"
<b>3/8" SQUARE DRIVE</b>										
105-D3*	3/8"	25 (34)	250	1.4 (0.64)	7.3 (186)	3 (85)	18 (510)	81.8/92.8	1/4"	3/8"
1105MAX-D3	3/8"	30 (41)	300	1.43 (0.65)	7.36 (187)	3.5 (99)	20 (566)	88.9/99.9	1/4"	3/8"

\*Not pictured.

### 105-D2

#### Air Ratchet Wrench

The Ingersoll Rand 105 series air ratchets offer professional technicians an outstanding combination of value and performance, delivering impressive comfort and durability.

- 25 ft-lb max torque
- Low profile forward/reverse control
- Head construction offers increased durability
- Ergonomic design



### 105-L2

#### Air Ratchet Wrench

The Ingersoll Rand 105 series air ratchets offer professional technicians an outstanding combination of value and performance, delivering impressive comfort and durability. The extended head of the 105-L2 offers longer reach.

- 25 ft-lb max torque
- Low profile forward/reverse control
- Head construction offers increased durability
- Ergonomic design



### 1105MAX-D2

#### Air Ratchet Wrenches

With the 1105MAX series air ratchets, you get best-in-class power and speed coupled with superior features to give you MAX power, MAX control, and MAX comfort.

(Also available in 3/8" drive: 1105MAX-D3)

#### MAX Power

30 ft-lb of torque combined with 300 rpm provides optimal torque/speed combination.

#### MAX Control

Easily accessible variable power regulator combined with feather touch lever offers unprecedented control.

#### MAX Comfort

Ergonomic coupling nut improves handle comfort and composite handle insulates against cold.



## Air Ratchet Repair Kits

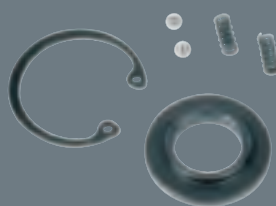

Keep your Ingersoll Rand air ratchet running strong with our genuine repair kits and parts — found on page 20.

## Air Ratchets

Model	Square Drive	Max Torque ft-lb (Nm)	Free Speed rpm	Weight lb (kg)	Length in (mm)	Average Air Consumption cfm (L/min)	Average Air Consumption @ Free Speed cfm (L/min)	Sound Pressure / Power dBA	AirInlet NPTF in	Min Hose Size in (mm)
<b>3/8" SQUARE DRIVE</b>										
107XPA	3/8"	54 (73)	160	2.75 (1.25)	11" (279)	4 (85)	19 (510)	94.4 / 100.4	1/4"	3/8"
109XPA	3/8"	76 (95)	220	3.3 (1.4)	12" (302)	4 (113)	24 (680)	92.4 / 103.4	1/4"	3/8"
1207MAX-D3	3/8"	65 (88)	200	3.2 (1.45)	10.8 (275)	4 (113)	23 (651)	85.0/96.0	1/4"	3/8"
<b>1/2" SQUARE DRIVE</b>										
1077XPA*	1/2"	54 (73)	160	2.75 (1.25)	11" (279)	4 (85)	19 (510)	94.4 / 105.4	1/4"	3/8"
1099XPA*	1/2"	76 (95)	220	3.3 (1.4)	12" (302)	4 (113)	24 (680)	92.4 / 103.4	1/4"	3/8"
1207MAX-D4*	1/2"	65 (88)	200	3.2 (1.45)	10.8 (275)	4 (113)	23 (651)	85.0/96.0	1/4"	3/8"

\*Not pictured.

### 107XPA

#### Air Ratchet Wrench

Based on the industry's most popular ratchet, the 107XPA delivers an extra measure of durability with an advanced head design, plus a host of other features.

- 54 ft-lb maximum torque
- 360° adjustable exhaust directs air away from the operator and the work
- Variable speed lever-style throttle



### 109XPA

#### Air Ratchet Wrench

Optimized gear ratio and airflow for extra performance, coupled with exceptional durability.

- 76 ft-lb maximum torque at 220 rpm free speed • 360° adjustable exhaust directs air away from the operator and the work
- Variable speed button trigger



### 1207MAX-D3

#### Air Ratchet Wrenches

As a member of the Ingersoll Rand family of MAX tools, the 1207MAX series air ratchets combine best-in-class performance and a full complement of premium features to give professional technicians MAX Power, MAX Control, and MAX Comfort. It's another in the long line of tools designed to help make your job easier — and you more productive.

(Also available in 1/2" drive: 1207MAX-D4)

<b>MAX Power</b>	65 ft-lb of maximum torque ensures enough power for tough applications.
<b>MAX Control</b>	Innovative forward/reverse collar, variable-speed power regulator, adjustable exhaust, and feather-touch trigger combine to offer unprecedented control.
<b>MAX Comfort</b>	Ergonomic composite handle is comfortable for extended use.



## Air Ratchet Boots



Even the industry's hardest-working air ratchets could use added protection from the rigors of the jobsite. Our air ratchet boots and accessories can be found on page 20

## Air Ratchet Accessories

Extend the life of your tools with genuine Ingersoll Rand repair kits and replacement parts. Every Ingersoll Rand part is specifically designed to enhance durability and improve the productivity of your tool.

### Air Ratchet Repair Kits

Part Number	For Use With
107XPA-SK	107XPA, 1077XPA
109XPA-SK	109XPA, 1099XPA



1077XPA-SK

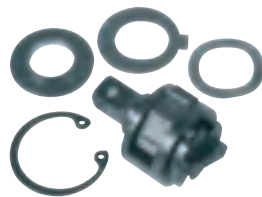

1107-TRK1

### Air Ratchet Head Repair Kits

Part Number	For Use With
103A-TRK-1	103A, 104B
1033A-TRK1	1033A
107XPA-TRK1	107XPA
1077XPA-TRK1	1077XPA
109XPA-TRK1	109XPA
1099XPA-TRK1	1099XPA
1105-D2-TRK1	1105MAX-D2, 105-D2, 105-L2
1105-D3-TRK1	1105MAX-D3, 105-D3
1207-D3-TRK1	1207MAX-D3
1207-D4-TRK1	1207MAX-D4
1215-TRK1	1215Ti
1225-TRK1	1225Ti

### Air Ratchet Tune-up Kits

Part Number	For Use With
107XPA-TK1	107XPA, 1077XPA
109XPA-TK1	109XPA, 1099XPA



1200-TK1

### Boots

Part Number	Description	For Use With
103-BOOT	Ratchet head boot with Ingersoll Rand logo printed on red boot	105-D2, 105-D3, 105-L2, 1105MAX-D2, 1105MAX-D3
107-BOOT	Ratchet head boot with Ingersoll Rand logo printed on red boot	107XP, 107XPA, 1077XP, 1077XPA, R380
109-BOOT	Ratchet head boot with Ingersoll Rand logo printed on red boot	109XP, 109XPA, 1099XP, 1099XPA



107-BOOT

# Sockets



Backed by a proud heritage of reliability and innovation, Ingersoll Rand introduces a comprehensive line of industrial-grade sockets consistent with the quality of our best-in-class Impacttools.

- Impact-grade chrome-molybdenum steel provides the durability you expect from a global leader
- Highly visible laser etching for easy size identification
- Nearly 800 Impactool socket items for virtually any assembly or disassembly job
- Lifetime warranty

From air compressors to Impacttools to sockets (and everything in between), Ingersoll Rand provides the toughest, highest quality products available.

## Features and Benefits

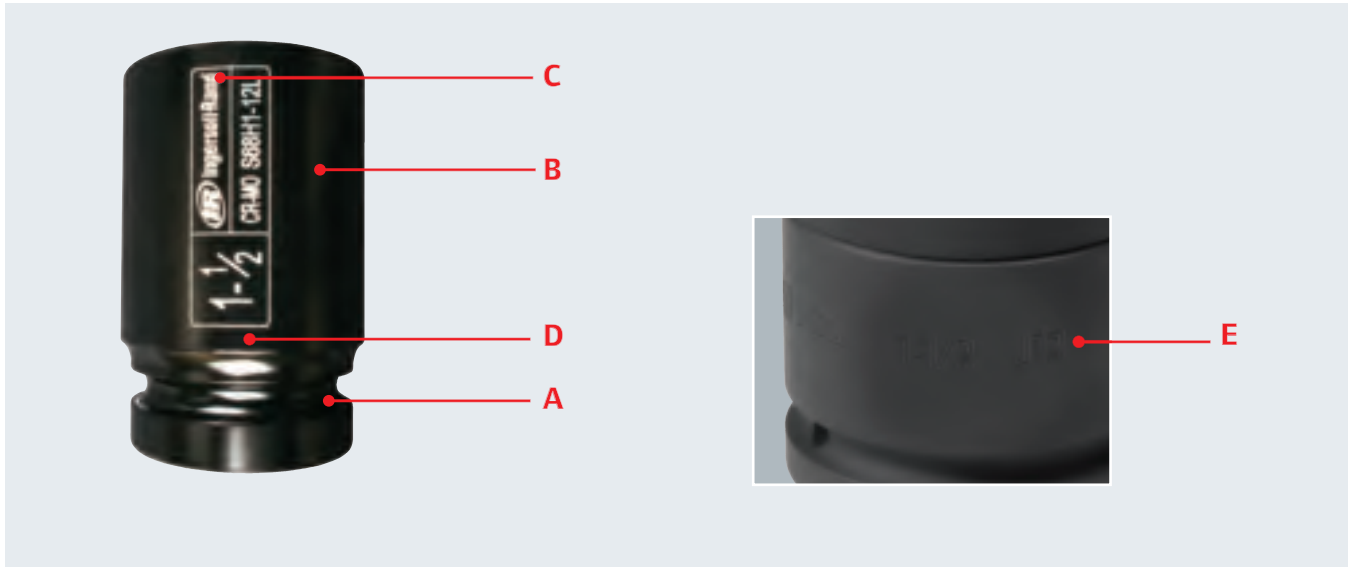

Features	Benefits
<b>A</b> Impact-grade toughness	Designed for high-torque applications
<b>B</b> Chrome-molybdenum steel	Forged for high-strength durability
<b>C</b> Laser-etched size labeling	Enables easy size identification
<b>D</b> Electro-phosphate finish on 1/4" to 1" drive sizes	Projects a sleek look and high visibility
<b>E</b> Durable roll stamp feature on 1-1/2", 2-1/2", and #5 Spline drive sizes	Enables easy size identification in harsh work environments
Backed by a Lifetime Warranty	Provides peace of mind with proven reliability

# Model Number Configurator

S64H78U  
SK3M8L

## Single Item

S	6	4	H	78	U
Socket Type	Output Type	Drive Size	SAE or Metric	Across Flats	Socket Length
A= Adapter E= Extension J= Universal Joint S= Socket	12= 12 point 6= 6 point	2= 1/4" 3= 3/8" 4= 1/2" 6= 3/4" 8= 1"	H= SAE M= Metric	SAE socket: i.e. 38= 3/8" (from 7/32" to 4-1/2") Metric socket: i.e. 20 (from 4mm to 125mm) Extensions: i.e. 3" (from 2" to 36")	L= Deep U= Universal UL= Universal Deep

## Socket Sets

S	K	3	M	8	L
Socket Type	Kit	Drive Size	SAE or Metric	Number of pieces per kit	Socket Length
S= Socket	K= Kit	2= 1/4" 3= 3/8" 4= 1/2" 34= Combo 3/8" & 1/2" 6= 3/4" 8= 1"	H= SAE M= Metric C= Combo SAE & Metric	3= 3 pieces 4= 4 pieces 5= 5 pieces 7= 7 pieces 8= 8 pieces 9= 9 pieces 10= 10 pieces 13= 13 pieces 14= 14 pieces 86= 86 pieces	L= Deep F= Flip U= Universal

## Industrial-grade Impact Sockets

Backed by a proud heritage of reliability and innovation, Ingersoll Rand introduces a comprehensive line of industrial-grade sockets consistent with the quality of our best-in-class Impacttools.

### Features and Benefits

Features	Benefits
A Impact-grade toughness	Designed for high-torque applications
B Chrome-molybdenum steel	Forged for high-strength durability
C Laser-etched size labeling	Enables easier identification to get the job done faster
D Electro-phosphate finish	Projects a sleeker look for higher visibility
E Backed by a lifetime warranty	Provides peace of mind with proven reliability

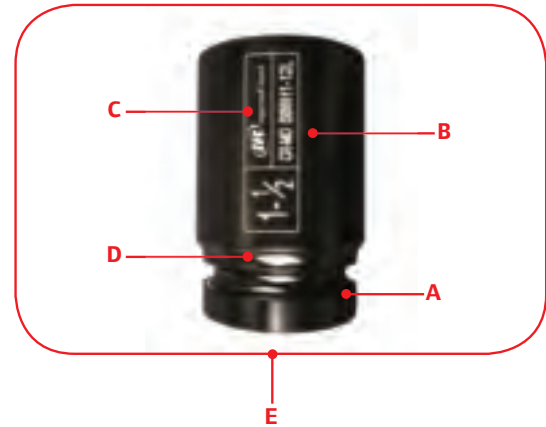

## 1/4" Square Drive Sockets

### Sets

Part Number	Pieces	Description	Contents
SK2C10	10	1/4" drive combo SAE and metric standard socket set	3/16", 1/4", 3/8", 1/2", 9/16", 4 mm, 6 mm, 10 mm, 12 mm, 14 mm
SK2M12	12	1/4" drive metric standard socket set	6 mm, 7 mm, 8 mm, 9 mm, 10 mm, 11 mm, 12 mm, 13 mm, 14 mm, 50 mm extension, 10 mm extension, 3/8" F to 1/4" M adapter



SK2C10



SK2M12

### Adapters

Part Number	Output Drive Size	Description
A2F3M	3/8"	1/4" F to 3/8" M
J2	1/4"	Universal joint



### Extensions

Part Number	Output Drive Size	Description
E22H	1/4"	2" extension
E24H	1/4"	4" extension
E26H	1/4"	6" extension



Ask your Ingersoll Rand representative or refer to catalog #IRITS-1210-087 for our full line of industrial grade sockets.



## 3/8" Square Drive Sockets

### Sets

Part Number	Pieces	Description	Contents
SK3H8	8	3/8" drive SAE standard socket set	5/16", 3/8", 7/16", 1/2", 9/16", 5/8", 11/16", 3/4"
SK3H8L	8	3/8" drive SAE deep socket set	5/16", 3/8", 7/16", 1/2", 9/16", 5/8", 11/16", 3/4"
SK3H7U	7	3/8" drive SAE universal socket set	3/8", 7/16", 1/2", 9/16", 5/8", 11/16", 3/4"
SK3M8	8	3/8" drive metric standard socket set	9 mm, 10 mm, 11 mm, 13 mm, 14 mm, 15 mm, 17 mm, 19 mm
SK3M8L	8	3/8" drive metric deep socket set	9 mm, 10 mm, 11 mm, 13 mm, 14 mm, 15 mm, 17 mm, 19 mm
SK3M10	10	3/8" drive metric standard socket set	9 mm, 10 mm, 11 mm, 12 mm, 13 mm, 14 mm, 15 mm, 16 mm, 17 mm, 19 mm
SK3M7U	7	3/8" drive metric universal socket set	10 mm, 12 mm, 13 mm, 14 mm, 15 mm, 17 mm, 19 mm
SK3C8	8	3/8" drive combo SAE and metric standard socket set	3/8", 1/2", 5/8", 11/16", 10 mm, 13 mm, 16 mm, 17 mm



### Adapters

Part Number	Output Drive Size	Description
A3F2M	1/4"	3/8" F to 1/4" M
A3F4M	1/2"	3/8" F to 1/2" M
J3	3/8"	Universal joint



### Extensions

Part Number	Output Drive Size	Description
E33H	3/8"	3" extension
E36H	3/8"	6" extension
E312H	3/8"	12" extension



## 1/2" Square Drive Sockets

### Sets

Part Number	Pieces	Description	Contents
SK4H13	13	1/2" drive SAE standard socket set	7/16", 1/2", 9/16", 5/8", 11/16", 3/4", 13/16", 7/8", 15/16", 1", 1-1/16", 1-1/8", 1-1/4"
SK4H13L	13	1/2" drive SAE deep socket set	7/16", 1/2", 9/16", 5/8", 11/16", 3/4", 13/16", 7/8", 15/16", 1", 1-1/16", 1-1/8", 1-1/4"
SK4H7U	7	1/2" drive SAE universal socket set	1/2", 9/16", 5/8", 11/16", 3/4", 13/16", 7/8"
SK4M14	14	1/2" drive metric standard socket set	10 mm, 11 mm, 12 mm, 13 mm, 14 mm, 15 mm, 16 mm, 17 mm, 18 mm, 19 mm, 21 mm, 22 mm, 26 mm, 27 mm
SK4M14L	14	1/2" drive metric deep socket set	10 mm, 11 mm, 12 mm, 13 mm, 14 mm, 15 mm, 16 mm, 17 mm, 18 mm, 19 mm, 21 mm, 22 mm, 26 mm, 27 mm
SK4M4L	4	1/2" drive metric deep axle nut service socket set	30 mm, 32 mm, 34 mm, 36 mm
SK4M7U	7	1/2" drive metric universal socket set	13 mm, 14 mm, 15 mm, 17 mm, 19 mm, 21 mm, 22 mm
SK4C3F	3	1/2" drive lug nut service flip socket set	3/4", 13/16", 19 mm x 21 mm, 3" extension
SK34C86	86	3/8" and 1/2" drive combo standard and deep socket set	Includes all sockets in SK3H8, SK3H8L, SK3M8, SK3M8L, SK4H13, SK4H13L, SK4M14, and SK4M14L
SK4M5L	5	1/2" drive deep socket set	17 mm, 19 mm, 21 mm, 22 mm, 24 mm
SK4M3L	3	1/2" drive metric deep protective socket set	17 mm, 19 mm, 21 mm
SK4M18	18	1/2" drive metric socket set	Standard: 10 mm, 11 mm, 13 mm, 14 mm, 17 mm, 19 mm, 21 mm, 22 mm, 24 mm Deep: 13 mm, 14 mm, 21 mm, 24 mm Deep Thin Wall: 17 mm, 19 mm, 21 mm, 125 mm extension, universal joint
SK4LNR	8	1/2" drive metric lug nut removal set	17 mm, 18.5 mm, 20 mm, 21.5 mm, 23 mm, 24.5 mm, 26 mm, 27.5 mm



### Adapters

Part Number	Output Drive Size	Description
A4F3M	3/4"	1/2" F to 3/8" M
A4F6M	3/4"	1/2" F to 3/4" M
J4	1/2"	Universal joint



### Extensions

Part Number	Output Drive Size	Description
E43H	1/2"	3" extension
E45H	1/2"	5" extension
E47H	1/2"	7" extension
E410H	1/2"	10" extension
E418H	1/2"	18" extra-long extension
E424H	1/2"	24" extra-long extension
E436H	1/2"	36" extra-long extension



## 3/4" Square Drive Sockets

### Sets

Part Number	Pieces	Description	Contents
SK6H8	8	3/4" drive SAE standard socket set	1", 1-1/16", 1-1/8", 1-1/4", 1-5/16", 1-3/8", 1-7/16", 1-1/2"
SK6H8L	8	3/4" drive SAE deep socket set	1", 1-1/16", 1-1/8", 1-1/4", 1-5/16", 1-3/8", 1-7/16", 1-1/2"
SK6M6L	6	3/4" drive metric deep socket set	24 mm, 27 mm, 30 mm, 32 mm, 33 mm, 36 mm



SK6H8



SK6H8L



SK6M6L

### Adapters

Part Number	Output Drive Size	Description
A6F4M	1/2"	3/4" F to 1/2" M
A6F8M	1"	3/4" F to 1" M
A6FS5M	#5 spline	3/4" F to #5 spline M
J6	3/4"	Universal joint



### Extensions

Part Number	Output Drive Size	Description
E63H	3/4"	3" extension
E67H	3/4"	7" extension
E610H	3/4"	10" extension
E613H	3/4"	13" extra-long extension



## 1" Square Drive Sockets

### Sets

Part Number	Pieces	Description	Contents
SK8H8	8	1" drive SAE standard socket set	7/8", 15/16", 1", 1-1/16", 1-1/8", 1-3/16", 1-1/4", 1-1/2"
SK8H8L	8	1" drive SAE deep socket set	7/8", 15/16", 1", 1-1/16", 1-1/8", 1-3/16", 1-1/4", 1-1/2"
SK8H9T	9	1" drive SAE truck service socket set	13/16" square; 7/8", 15/16", 1", 1-3/16", 1-1/2" hex; 1-1/16", 1-1/8", 1-1/4" deep thin wall hex
SK8C5T	5	1" drive combo SAE and metric deep truck service socket set	13/16" square; 33 mm & 1-1/2" deep hex; 1-1/8" and 1-1/4" deep thin wall hex
SK8M4L	4	1" drive metric deep socket set	27 mm, 30 mm, 32 mm, 33 mm



SK8H8



SK8H8L



SK8H9T



SK8C5T



SK8M4L

### Adapters

Part Number	Output Drive Size	Description
A8F6M	3/4"	1" F to 3/4" M
A8F12M	1-1/2"	1" F to 1-1/2" M
A8FS5M	#5 spline	1" F to #5 spline M
J8	1"	Universal joint



### Extensions

Part Number	Output Drive Size	Description
E83H	1"	3" extension
E87H	1"	7" extension
E810H	1"	10" extension
E813H	1"	13" extra-long extension



# Air Grinders and Cutting Tools



With high-strength steels, advanced plastics, and new composite materials in today's cars and trucks, you need versatile tools for precise, controlled cutting. Ingersoll Rand cutting tools are the reliable choice of auto body and repair shops, used for everything from muffler and exhaust work to sunroof installations and body repairs.



## Air Grinders

Model	Rated Power hp (kW)	Free Speed rpm	Output	Weight lb (kg)	Length in (mm)	Air Consumption cfm (L/min)	Average Air Consumption @ Load cfm (L/min)	Sound Pressure / Power dBA	Air Inlet NPTF in	Min Hose Size in (mm)
301	0.25 (0.19)	21,000	1/4" Collet	0.99 (0.45)	5.0" (127)	6 (170)	25 (707)	91.8 / 104.8	1/4"	3/8" (10)
302A	0.25 (0.19)	18,000	1/4" Collet	0.97 (0.44)	5.0" (127)	3 (85)	12 (340)	94 / 105	1/4"	3/8" (10)
307A	0.25 (0.19)	28,000	1/4" Collet	0.69 (0.31)	4.8" (121)	6 (170)	25 (707)	83 / 94	1/4"	3/8" (10)
308A	0.5 (0.37)	25,000	1/4" Collet	1.16 (0.53)	5.6" (143)	3 (85)	20 (566)	91 / 102	1/4"	3/8" (10)

### 301

#### Multi-purpose Air Angle Die Grinder

Part of an expanded line of economical, heavy-duty grinders, the 301 packs valuable features into a compact package. Use it for grinding, edge-breaking, deburring, porting, and polishing. Wherever space is tight, its right-angle configuration provides easy access.

- Compact, lightweight, and easy to handle
- Self-locking throttle
- Precision-machined gearing delivers maximum power transfer



### 302A

#### Air Angle Die Grinder

When a straight tool isn't practical for working in confined areas, this economical die grinder with a right-angle head is the one to use. It's compact and well-designed for grinding, porting, polishing, deburring, and breaking sharp edges.

- Precision-machined steel gears
- Positive grip 1/4"-capacity collet chuck
- Self-locking throttle lever



### 307A

#### Mini Air Die Grinder

The 307A combines performance and versatility in a lightweight, compact package. It can be used with all types of accessories for porting, weld breaking, and smoothing sharp edges, as well as deburring, polishing, and grinding.

- Standard 1/4" collet for all types of accessories
- Safety lever prevents accidental starts
- Front exhaust helps keep work surface clean



### 308A

#### Air Die Grinder

A durable yet economical choice offering longer life and higher free speed at 25,000 rpm, this general-purpose tool is designed for porting, light weld grinding, and breaking sharp edges.

- Comes with two collet wrenches
- Self-locking throttle lever
- Positive grip 1/4"-capacity collet chuck



## Carbide Grinding Burr Kits



Our carbide burs set the industry standard for quality, and come in a variety of types, styles, and sizes. See pages 33 and 34 for our complete line of Ingersoll Rand air cutting tools and grinder accessories.

## Air Grinders

Model	Rated Power hp (kW)	Free Speed rpm	Output	Weight lb (kg)	Length in (mm)	Average Air Consumption cfm (L/min)	Air Consumption @ Load cfm (L/min)	Sound Pressure / Power dBA	Air Inlet NPTF in	Min Hose Size in (mm)
3102	0.33 (0.25)	20,000	1/4" Collet	1.27 (.58)	6.75" (171)	3 (85)	18 (510)	90 / 101	1/4"	3/8" (10)
3108	0.33 (0.25)	25,000	1/4" Collet	1.27 (.58)	6.75" (171)	3 (85)	18 (510)	92 / 103	1/4"	3/8" (10)
326	N/A	20,000	N/A	2.3 (1.04)	8.88" (226)	10 (283)	25 (708)	94.3 / 107.3	1/4"	3/8" (10)
345MAX* 0.88 (0.66)		12,000	5/8" - 11 Thread	3.44 (1.56)	9.6" (244)	10 (283)	41 (1,160)	79.6 / 90.6	1/4"	3/8" (10)
3445MAX 0.88 (0.66)		12,000	5/8" - 11 Thread	3.37 (1.53)	9.6" (244)	10 (283)	41 (1,160)	79.6 / 90.6	1/4"	3/8" (10)
MINI TOOL SURFACE PREP GRINDER										
3103XP	0.2 (0.15)	15,000	1/4" - 20 Thread	0.99 (0.45)	5" (125)	2.1 (59)	19.4 (549)	84.9 / 95.9	1/4"	3/8" (10)

\*Not pictured.

### 3102

#### Composite Die Grinder

For the ultimate performance and versatility in a lightweight package with superior maneuverability, these grinders are the perfect choice. The 3102 features a composite grip for superior ergonomics and comfort. These powerful die grinders can be used in various applications including porting, weld braking, deburring, polishing, and grinding, just to name a few.

- 20,000 rpm
- Safety release throttle
- Positive grip 1/4"-capacity collet chuck



### 3108

#### Composite Die Grinder

The 3108 features a composite grip for superior ergonomics and comfort. These powerful die grinders can be used in various applications including porting, weld braking, deburring, polishing, grinding, and more.

- 25,000 rpm
- Safety release throttle
- Positive grip 1/4"-capacity collet chuck



### 3445MAX

#### Air Angle Grinder

The 3445MAX is the perfect choice for high performance material removal. This 4.5" air angle grinder combines a unique internal governor with a powerful 0.88 hp motor, to give you a best-in-class power to weight ratio grinder that will maximize your rate of material removal. (Also available in 5" 345MAX)

**MAX Power** 0.88 hp and 12,000 rpm motor delivers the power you need to grind through the toughest job.

**MAX Productivity** Internal governor maximizes speed under load, increasing your rate of material removal.

**MAX Comfort** Lower weight and enhanced grip design enables extended usage without fatigue.



### 326

#### Cut-off Tool

The heavy-duty cut-off tool is designed for durability and on-the-job performance. Ideal for cutting mufflers, tail pipes, sheet metal, nuts, and bolts.

- Provides 18,000 rpm for fast cutting
- Steel shield deflects debris away from operator
- Large hooked locking throttle lever provides user comfort and safety



### 3103XP

#### Mini Surface Prep Sander

Whether you're working in tight spaces or doing finely detailed finish work, our mini tools deliver the power, versatility, and durability you want, in a conveniently smaller size.

- Ball-bearing construction enhances durability and smooth power delivery
- Double-sided, adjustable speed settings provide variability for a broader range of applications
- includes 2" and 3" medium backing pads



Remove rough spots quickly and easily

### 3103K

#### Mini Surface Prep Sander Kit

## Abrasive Convenience Packs



In addition to our abrasive convenience packs, Ingersoll Rand offers a line of 2" and 3" surface conditioning discs designed to maximize the productivity of our air grinders while ensuring the best possible finishes. See pages 33 and 34 for our full line of cutting tool and grinder accessories.

## Surface Conditioning Kits

### 301-2MK

#### Surface Conditioning Kit

Ingersoll Rand has packed the 301 in a strong, blow-molded plastic case along with four coarse and four medium grit 2" Roloc™ surface conditioning pads and a disc holder.



### 301-32MK

#### Surface Conditioning Kit

This kit contains the 301 in a strong, blow-molded plastic case along with two coarse and two medium grit 3" Roloc surface conditioning pads, two coarse, two medium grit 2" Roloc surface conditioning pads, and two disc holders.



### 301-3MK

#### Surface Conditioning Kit

Four coarse and four medium grit 3" Roloc surface conditioning pads are packed in a strong blow-molded case with our popular 301 grinder.



### 301-K

#### Die Grinder Kit

Ingersoll Rand has packed the 301 in a strong, blow-molded plastic case complete with 10 mounted grinding tips.



### 3102K

#### Die Grinder Kit

For the ultimate performance and versatility in a lightweight package with superior maneuverability in an angle grinder, the 3102 is the perfect choice. The 3102 features a composite grip for superior ergonomics and comfort. This powerful grinder can be used in a variety of applications, including porting, weld braking, deburring, grinding, polishing, etc. The kit includes the 3102 Grinder, 2" and 3" Quick Change Backing Pads, along with a variety of 2" and 3" Quick Change Sanding Disks, 2" and 3" Quick Change Coarse and Medium Polishing Disks, all packaged in a strong, blow-molded plastic case.



### 307-K

#### Die Grinder Kit

The 307-K comes with 10 mounted grinding tips in a strong, blow-molded case.



### 4102K

#### Surface Preparation Kit

Along with the versatile, lightweight, and powerful 3102 Angle Grinder, this Kit comes along with the ultimate in Random Orbital Sanders, the 4151-HL. The 4151-HL adds to the Kit the benefit of a lightweight, 6" pad, 12,000 RPM, vacuum-ready, random orbital sander for all of the fine-finish requirements for the job at hand. Along with the Angle Grinder and the Random Orbital Sander, the kit includes a 3" Quick Change Backing Pad, 3" Quick Change Sanding Disks, 3" Quick Change Coarse and Medium Polishing Disks, a 6" Hook and Loop Backing Pad, and 6" Sanding Disks, all packaged in a strong, blow-molded plastic case.



### 3108K

#### Die Grinder Kit

The 3108 features a composite grip for superior ergonomics and comfort. These powerful die grinders can be used in various applications including porting, weld braking, deburring, polishing, grinding, and more.



## Air Cutting Tools

Model	Strokes Per Minute	Weight lb (kg)	Length in (mm)	Average Air Consumption cfm (L/min)	Air Consumption @ Load cfm (L/min)	Sound Pressure / Power dBA	Air Inlet NPTF in	Min Hose Size in (mm)
7802SA	4,200	2.8 (1.27)	9.4" (239)	4 (113)	21 (595)	N/A	1/4"	3/8" (10)
325B	3,200	2.1 (0.95)	7.3" (185)	4 (113)	17 (481)	90.2 / 103.2	1/4"	3/8" (10)
429	10,000	1.3 (0.6)	8.3" (210)	8 (226)	9 (255)	84.3 / 95.3	1/4"	1/4" (6)
4429*	5,750	1.6 (0.74)	9.3" (235)	4 (113)	7.6 (215)	66.2 / 77.2	1/4"	1/4" (6)

\*Not pictured.

### 7802SA

#### Air Shear

This versatile cutting shear that makes clean cuts in cold-rolled steel up to 20-gauge without chips is ideal for body shops, sheet metal shops, air-conditioning fabricators, plastic fabricators, heating contractors, and machine shops.

- Cuts squares, angles, and circles
- Long-life tool with heavy-duty cutting blades
- Shears most types of plastics and all types of aluminum, tin, and steel



### 325B

#### Air Nibbler

Get a bigger bite and better angle cuts with our Air Nibbler. Instead of shearing or sawing, the tool actually "nibbles" cold-rolled steel, plastic, tin, aluminum, and other metals, up to 18-gauge thicknesses at a rate of more than 6' per minute. It's ideal for paint and auto body shops, tinsmiths, and sheet metal shops.

- Cuts out quarter panels without distorting the edges of the material
- Starts cuts in the center of a panel
- Holds a tight 1/4" radius with great accuracy



### 429

#### Air Reciprocating Saw

The 429 is a versatile air saw for cutting intricate shapes and light radius curves in all types of plastics, fiberglass, and composite materials, as well as aluminum and sheet metal. This reduced vibration tool is excellent for body shop repair, muffler and exhaust work, and sunroof installations.

- Comes with 6 high-speed steel cutting blades and 2 hex wrenches
- Cuts flat and curved surfaces
- Durable, long-life tool



## Saw Blades



Saw blades, cutting tools, and all other grinder accessories can be found on pages 33 and 34.



## Carbide Grinding Burr Kits

Ingersoll Rand carbide burrs are titanium nitride (TiN) coated to provide maximum edge retention and corrosion resistance. The TiN coating can improve the average lifetime of the burr by more than three times.

*Note: Burrs have a maximum operating speed of 40,000 rpm.*



1814TiN



1438TiN



M30TiN

The 30 piece, carbide burr mega set covers a wide range of applications. Handy storage box keeps burrs organized and ready for use.

Part Number	Description	
1814TiN	6-piece carbide burr kit	TiN coated carbide burrs — 1/8" shank, 1/4" head diameter with soft-sided case
618TiN	6-piece carbide burr kit	TiN coated carbide burrs — 1/8" shank, 1/4" and 1/8" head diameters with soft-sided case
1818TiN	6-piece carbide burr kit	TiN coated carbide burrs — 1/8" shank, 1/8" head diameter with soft-sided case
1816TiN	6-piece carbide burr kit	TiN coated carbide burrs — 1/8" shank, various head diameters with soft-sided case
1438TiN	6-piece carbide burr kit	TiN coated carbide burrs — 1/4" shank, 3/8" head diameter with soft-sided case
614TiN	6-piece carbide burr kit	TiN coated carbide burrs — 1/4" shank, 1/2" and 3/8" head diameters with soft-sided case
1412TiN	6-piece carbide burr kit	TiN coated carbide burrs — 1/4" shank, 1/2" head diameter with soft-sided case
814TiN	8-piece carbide burr kit	TiN coated carbide burrs — 1/4" shank, 1/2" and 3/8" head diameters with hard case
M30TiN	30-piece carbide burr mega set	TiN coated carbide burrs — 1/4" and 1/2" shank, various head diameters and shapes with hard case

## Abrasive Convenience Packs

Part Number	Description
<b>SANDING VARIETY GRIT PACKS</b>	
02A-VARAO-6	2" AO Series sanding discs — 2 each 36, 50, 80 grit
03A-VARAO-6	3" AO Series sanding discs — 2 each 36, 50, 80 grit
02A-VARCO-6	2" CO Series sanding discs — 2 each 36, 50, 80 grit
03A-VARCO-6	3" CO Series sanding discs — 2 each 36, 50, 80 grit
23A-VARAO-6	2" and 3" AO Series sanding discs — 1 each 36, 50, 80 grit
<b>SURFACE CONDITIONING / VARIETY GRIT PACKS</b>	
02A-VARBR-5	2" surface preparation discs — 2 each coarse and medium, 1 very fine
03A-VARBR-5	3" surface preparation discs — 2 each coarse and medium, 1 very fine
23A-VARBR-6	2" and 3" surface preparation discs — 1 each coarse, medium, 1 very fine
<b>HIGH STRENGTH — BLENDING AND BUFFING DISCS</b>	
02A-MEDHS-4	2" medium-grade, blending kit 3 discs with backing pad and post
03A-MEDHS-4	3" medium-grade, blending kit 3 discs with backing pad and post
<b>QUICK STRIP — PAINT AND CORROSION DISCS</b>	
02A-CRSBS-4	2" coarse quick-strip kit 3 discs with backing pad and post
03A-CRSBS-4	3" coarse quick-strip kit 3 discs with backing pad and post
<b>COMPLETE SURFACE CONDITIONING KITS</b>	
02A-VAR-KIT	2" complete surface preparation kit with backing pad and post
03A-VAR-KIT	3" complete surface preparation kit with backing pad and post



## Cut-off Wheels

Part Number	Description
9520	3" diameter cutting discs (5 pack)
9521	3" diameter cutting discs (50 pack)



## Bi-metal Reciprocating Saw Blades

These Bi-metal technology blades are created using a solid-state diffusion process that applies high-speed steel to both edges of the backing material, which increases the contact area by 170 percent. Bi-metal blades have a new tooth profile that generates more (but smaller) chips: this reduces frictional heat that is generated during the cutting application, which will enhance overall performance.

Part Number	Description	Teeth Per Inch	Quantity
<b>FINE</b>			
P4FS-6	Fine standard pitch	32	6
P4FS-20	Fine standard pitch	32	20
P4FS-50	Fine standard pitch	32	50
<b>COARSE</b>			
P4CS-6	Coarse standard pitch	24	6
P4CS-20	Coarse standard pitch	24	20
P4CS-50	Coarse standard pitch	24	50
<b>EXTRA COARSE</b>			
P4EV-6	Extra-coarse variable pitch	14 – 18	6
P4EV-20	Extra-coarse variable pitch	14 – 18	20
P4EV-50	Extra-coarse variable pitch	14 – 18	50



# Air Finishing Tools

A close-up photograph of a technician with a beard and safety glasses, wearing a grey long-sleeved shirt, using a red and black air finishing tool on a red car. The tool is being applied to a chrome trim piece. The background is dark and out of focus.

Ingersoll Rand has the industry's most complete line of air finishing tools. Sanders, polishers, and buffers come in a variety of models from traditional styles for heavy material removal to the newest models for excellent control and brilliant surfaces. All Ingersoll Rand finishing tools are designed for long-life and swirl-free finishes.

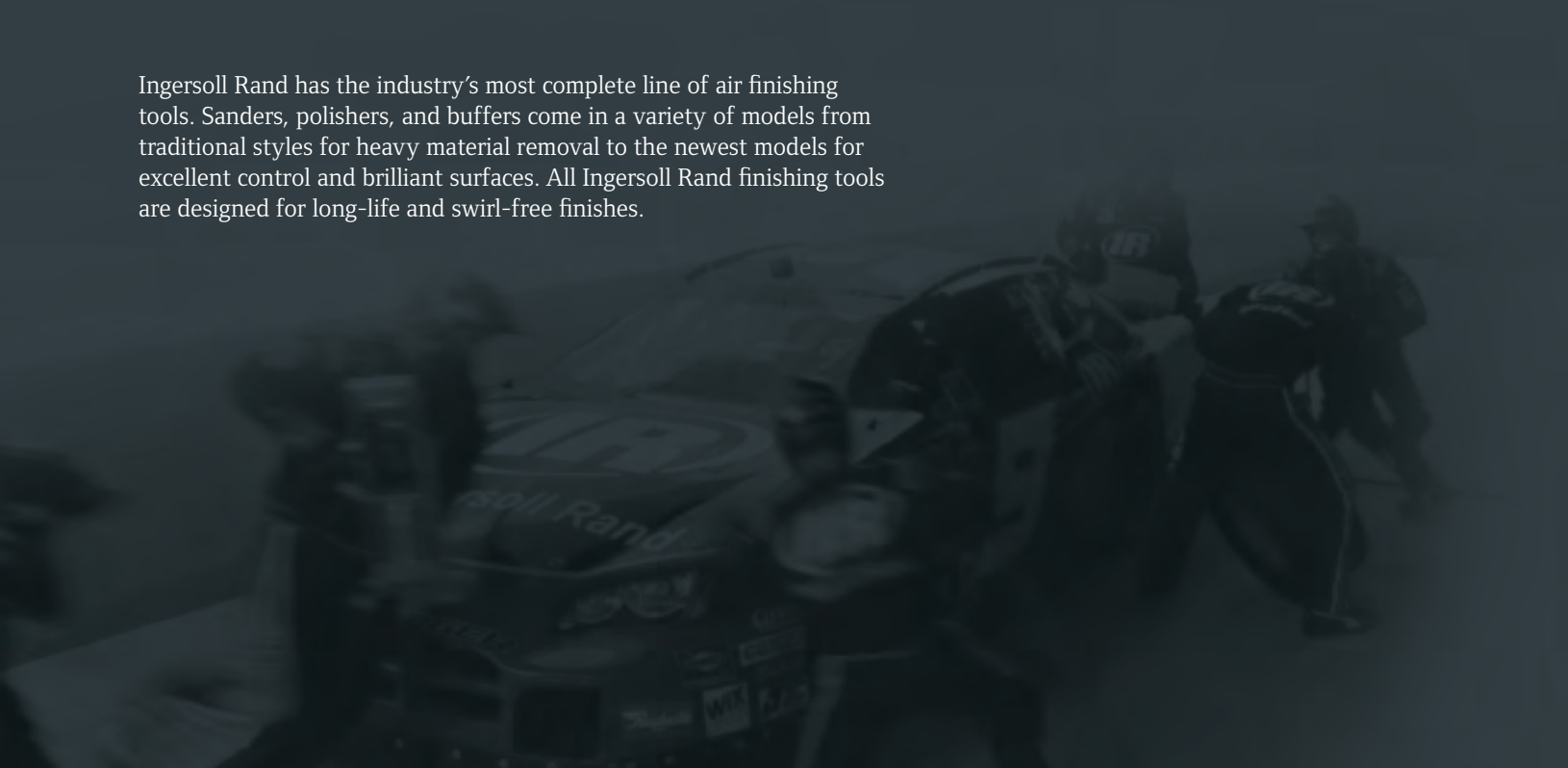
A collection of various air finishing tools, including sanders, polishers, and buffers, arranged on a dark surface. The tools are shown in a variety of orientations, some with their handles and others with their heads. The background is dark and out of focus.

Ingersoll Rand

## Air Finishing Tools

Model	Free Speed rpm	Rated Power hp (kW)	Pad Size in (mm)	Weight lb (kg)	Average Air Consumption cfm (L/min)	Air Consumption @ Load cfm (L/min)	Sound Pressure / Power dBA	Chuck Size in (mm)	Air Inlet NPTF in	Min Hose Size in (mm)
327*	22,000	0.5 (0.38)	N/A	1.6 (.73)	15 (425)	28 (793)	90.9 / 103.9	3/8" (10)	1/4"	3/8" (10)
327LS	3,000	0.5 (0.37)	N/A	1.13 (.51)	14 (396)	27 (765)	95 / 108	3/8" (10)	1/4"	3/8" (10)
312A	8,000	0.3 (0.22)	3-2/3" x 6-3/4" (93 x 171)***	4.6 (2.09)	9 (255)	12 (340)	94.1 / 107.1	N/A	1/4"	3/8" (10)
317A	18,000	N/A	5" (127)	2.3 (1.04)	12 (340)	25 (708)	86.7 / 99.7	N/A	1/4"	3/8" (10)
315	3,000**	N/A	2-3/4" x 17-1/2" (70 x 445)***	6.6 (2.99)	8 (226)	9 (255)	93.3 / 106.3	N/A	1/4"	3/8" (10)

\*Not pictured. \*\*1" length strokes per minute. \*\*\*Rectangular pad size.

### 327LS

#### Low-speed Air Tire Buffer

Designed for convenience, the many features of the 327LS make it an ideal tool for every tire shop. The quick-change chuck, built-in regulator, and lever-style throttle make patchwork, roughing areas for recapping, and cleaning tire moldings a breeze.

- Trigger design with lock-off feature allows for easy operation and protection from accidental start-up
- Piped-away exhaust (included) directs air away from work area and operator
- Convenient hanger keeps tool within easy reach



### 312A

#### Orbital Air Sander 3-2/3" x 6-3/4" Pad

The 312A air orbital sander has a free speed up to 8,000 rpm to make fast work of smoothing fiberglass, wood, and body filler, and to take care of any sanding job on paint, metal, and fiberglass. Plus, you can run the 312A with one hand, using the compact, contoured palm-grip.

- Balanced ball bearing construction
- Automatic release throttle lever with positive stop action
- Built-in regulator for positive speed control

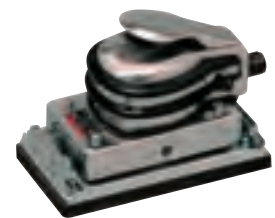

### 317A

#### High-speed Air Sander 5" Pad

For small jobs and hard-to-reach places, the 317A is an economical high-speed sander ideal for light sanding, feather edging, and rust removal.

- Easy to handle, compact, and lightweight
- Built-in power regulator
- Comes with two backing pads; one is 3", and the other is 5" (stackable)



### 315

#### Twin-piston Straight-line Air Sander 2-3/4" x 17-1/2" Pad

The twin-piston design keeps extra power in reserve to prevent stalling and tackle sanding jobs like smoothing down body filler or shaping and leveling large, flat surfaces.

- 3,000 reciprocating strokes per mi
- Quick-action paper clamps
- Smooth, reliable power



## Straight-line Sanding Pads



Constructed with non-metallic material to reduce side strap wear, our straight-line sanding pads are designed specifically for the Ingersoll Rand 315 straight-line sander. See pages 40 for our full line of finishing tool accessories.

Model	Free Speed rpm	Rated Power hp (kW)	Pad Diameter in (mm)	Weight lb (kg)	Output	Average Air Consumption cfm (L/min)	Air Consumption @ Load cfm (L/min)	Sound Pressure / Power dBA	Air Inlet NPTF in	Min Hose Size in (mm)
311A	12,000	0.25 (0.191)	6" (150)	4.2 (1.91)	5/16" – 24 Thread	4 (113)	17 (481)	85.6 / 98.6	1/4"	3/8" (10)
328B	825	0.25 (0.191)	8" (203)	4.7 (2.13)	N/A	4 (113)	16 (453)	90.45 / 93.7	1/4"	3/8" (10)
313A	5,000	0.5 (0.37)	7" (175)	4.5 (2.04)	5/8" – 11 Thread	8 (226)	29 (651)	99.3 / 112.3	1/4"	3/8" (10)
314A*	2,500	0.4 (0.30)	7" (175)	4.5 (2.04)	5/8" – 11 Thread	8 (226)	29 (623)	97.3 / 110.3	1/4"	3/8" (10)
318A	2,800	1 (0.746)	7" (175)	4.5 (2.04)	5/8" – 11 Thread	6 (170)	21 (595)	90.5 / 103.5	1/4"	3/8" (10)
319A*	5,000	N/A	7" (175)	4.5 (2.04)	5/8" – 11 Thread	6 (170)	20 (566)	90.8 / 103.8	1/4"	3/8" (10)
MINI AIR FINISHING TOOLS										
3128XP	15,000	0.2 (0.15)	3" (76.2)	1.1 (0.5)	1/4" – 20 Thread	2.1 (58)	14.7 (416)	84.2 / 96.9	1/4"	3/8" (10)
3129XP	6,000	0.3 (0.22)	3" (76.2)	1.3 (0.6)	1/4" – 20 Thread	2.2 (62)	19.9 (561)	83.5 / 94.5	1/4"	3/8" (10)

\* 314A air angle polisher / buffer and 319A sander not pictured.

## 311A

### Dual-action Quiet Air Sander — 6" Pad

A built-in silencer muffles noise as you work with this economical dual-action sander. It's a quality sander used for feather edging, metal preparation, and finish work on body filler. And its dual-action pad motion produces swirl-free finishes.

- Low vibration
- Balanced ball bearing construction
- Adjustable built-in regulator for positive speed control



## 328B

### Gear-driven Orbital Air Sander — 8" Pad

The smooth strength and power of this air-gear-driven orbital sander lets you remove heavy material and body filler on large, flat surfaces leaving a clean, swirl-free finish.

- Dual-action pad motion (5/32" orbit)
- Long-life, low-vibration performance
- Balanced ball bearing construction



## 313A

### Angle Air Sander — 7" Pad

With up to 5,000 rpm free speed, you can work faster on light and heavy sanding jobs, including roughing body filler, removing rust, and smoothing welds.

- Heavy-duty motor handles tough jobs
- Lightweight, only 4.5 lb
- Ball bearing construction for long life



## 318A

### Vertical Air Polisher / Buffer — 7" Pad

Buff and polish all painted surfaces easily. This compact, lightweight vertical polisher / buffer gives you the results you want. The variable speed control lever throttle helps eliminate paint burning. Comes complete with a 7" backing pad.

- Long tool life from the planetary gear reduction feature
- Plenty of power from the 1 hp motor
- Handle exhaust directs air away from work area



## 3128XP

### Mini Random Orbital Sander

- Delivers swirl-free finishes when feather edging, removing rust, preparing metal surfaces, or smoothing welds
- Durable ball-bearing construction ensures smooth power delivery
- Includes 3" hook and loop style backing pad



Sands smoothly, leaving no swirl marks behind

## 3129XP

### Mini Polisher

- Free speed of 6,000 rpm delivers the same performance of polishers twice the size
- Double-sided, adjustable speed settings provide variability for a broader range of applications
- Includes 3" hook and loop style backing pad



Ideal for a smooth, professional finish

## 3128K

### Mini Random Orbital Sander Kit

- Includes 71-piece hook and loop discs

## 3129K

### Mini Polisher Kit

- Includes 4-piece hook and loop pads

## Air Finishing Tools

Model	Free Speed rpm	Rated Power hp (kW)	Pad Diameter in (mm)	Orbit Diameter in (mm)	Weight lb (kg)	Average Air Consumption cfm (L/min)	Air Consumption @ Load cfm (L/min)	Sound Pressure / Power dBA	Air Inlet NPTF in	Min Hose Size in (mm)
4151	12,000	0.2 (0.15)	6" (150)	3/16" (5)	1.92 (.87)	8 (226)	15.5 (439)	81.6 / 91	1/4"	5/16" (8)
4151-5*	12,000	0.2 (0.15)	5" (125)	3/16" (5)	1.92 (.87)	8 (226)	15.5 (439)	81.6 / 91	1/4"	5/16" (8)
4151-HL*	12,000	0.2 (0.15)	6" (150)	3/16" (5)	1.92 (.87)	8 (226)	15.5 (439)	81.6 / 91	1/4"	5/16" (8)
4151-2*	12,000	0.2 (0.15)	6" (150)	3/16" (5)	2.4 (1.1)	8 (226)	15.5 (439)	81.6 / 91	1/4"	5/16" (8)
4152	12,000	0.2 (0.15)	6" (150)	3/32" (2.5)	1.92 (.87)	8 (226)	15.5 (439)	81.6 / 91	1/4"	5/16" (8)
4152-HL*	12,000	0.2 (0.15)	6" (150)	3/32" (2.5)	1.92 (.87)	8 (226)	15.5 (439)	81.6 / 91	1/4"	5/16" (8)

\*Not pictured.

NOTE: HL models include a hook-and-loop pad.

### 4151

#### Vacuum-ready Random Orbital Air Sander

This vacuum-ready, low-vibration model produces an ultra high-quality finish and connects easily to central or portable vacuum systems. The 4151 extracts dust and particles through and around the pad, keeping foreign matter away from the motor. The vacuum sanding pad features a unique design with large 1/2" holes for efficient operation. Virtually all dust is instantly channeled away from the work.

- 12,000 rpm free speed for swirl-free finishes
- Durable, lightweight composite design weighs less than 2 lb
- 3/16" orbit diameter



### 4152

#### Vacuum-ready Random Orbital Air Sander

The 4152 sets a new standard in elite automotive finish work. This fine 3/32" orbit sander helps users achieve high-quality paint finishes. The 4152 utilizes a precision ground counterbalance to reduce vibration.

- 12,000 rpm free speed for swirl-free finishes
- Durable, lightweight composite design weighs less than 2 lb
- 3/32" orbit diameter



## Vacuum Kits



Keep your work surface and area clean with our Jet-Vac dust extraction system and accessories. See page 39 for more information. Turn to page 40 for all other major components and accessories.

## Vacuum Kits and Accessories

Influenced by jet engine technology, the Ingersoll Rand Jet-Vac dust extraction system sucks up more air than it takes to actually run the tool. Perfect for use with our sanders.

Part Number	Description	For Use With
<b>JET-VAC CONVERSION KITS</b>		
4151JV	Jet-Vac conversion kit	4151, 4152 Series, Cyclone Standard, Cyclone Select, CycloVAC sanders
RSVK-5*	5" Jet-Vac conversion kit	4151, 4152 Series, Cyclone Standard, Cyclone Select, CycloVAC sanders
RSVK-6*	6" Jet-Vac conversion kit	4151, 4152 Series, Cyclone Standard, Cyclone Select, CycloVAC sanders

\*Not pictured.

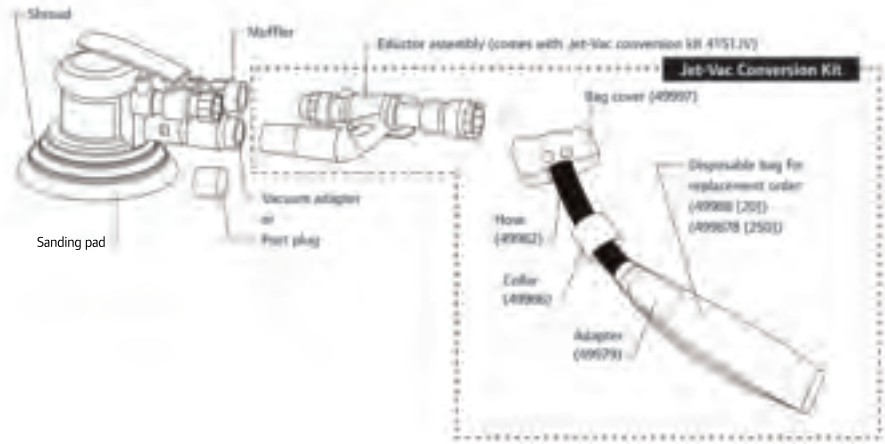

Air Finishing Tools

Part Number	Description	For Use With
<b>JET-VAC ACCESSORIES</b>		
49600*	6' (1.8 m) hose equipped with molded 1" ID cuffs at each end	4151, 4152 Series, Cyclone Standard, Cyclone Select, CycloVAC sanders
49973	Disposable vacuum bag (single)	4151, 4152 Series, Cyclone Standard, Cyclone Select, CycloVAC sanders
49997	Bag cover	4151, 4152 Series, Cyclone Standard, Cyclone Select, CycloVAC sanders
355-402*	Dust collection bag	4151, 4152 Series, Cyclone Standard, Cyclone Select, CycloVAC sanders
49979	Vacuum adapter	4151, 4152 Series, Cyclone Standard, Cyclone Select, CycloVAC sanders
49982	Vacuum hose	4151, 4152 Series, Cyclone Standard, Cyclone Select, CycloVAC sanders
49986*	Vacuum hose collar	4151, 4152 Series, Cyclone Standard, Cyclone Select, CycloVAC sanders
49987*	Disposable vacuum bags (250 pack)	4151, 4152 Series, Cyclone Standard, Cyclone Select, CycloVAC sanders
49988*	Disposable vacuum bags (20 pack)	4151, 4152 Series, Cyclone Standard, Cyclone Select, CycloVAC sanders

\*Not pictured.



## 4100 Series Major Components and Accessories

Model	Description
<b>NON-VACUUM PADS 3/8"</b>	
49879-1	6" vinyl
49094-1	5" vinyl
49877-1	5" duck
<b>VACUUM PADS 3/8"</b>	
VPAD-6	6" petal pattern
49694	6" hook-and-loop
49096-1	5" petal pattern
<b>VACUUM ADAPTER FOR MODEL 3154</b>	
4151-A809A-25	Vacuum adapter
<b>SHROUDS</b>	
48266-1	Short (standard on 4151)
48878	Long
<b>JET-VAC VACUUM BAGS</b>	
49988	Disposable bags (20 pack)
49987	Disposable bags (250 pack)
<b>JET-VAC CONVERSION KIT</b>	
4151JV	6" pad 48878 - (1) 6" shroud 49976 - (1) eductor assembly 49973 - (3) disposable bags 49979 - (1) bag adapter 49997 - (1) cloth bag cover 49982 - (1) hose 49986 - (1) collar
<b>SERVICE KIT (FOR PREVENTIVE MAINTENANCE)</b>	
30131-2	IR49837 pad wrench (included with every tool)
<b>SPANNER WRENCH</b>	
44548	Use to remove the lock ring securing the motor assembly

Model	Diameter	Description
<b>BACKING PADS FOR MODELS 313, 314, 318, 319</b>		
313A-825-7	7"	Standard-duty - rigid backing pad
6130A	7"	Heavy-duty - flexible backing pad
<b>DUAL-ACTION BACKING PADS FOR MODELS 310 AND 311</b>		
311A-825-6	6"	Standard-duty - vinyl pad
6120A	6"	Heavy-duty - firm edge for firm support, cloth back
6121A	6"	Heavy-duty - soft edge for medium support, cloth back
6122A	5"	Heavy-duty - firm edge for firm support, cloth back
6123A	5"	Heavy-duty - soft edge for medium support, cloth back
<b>DUAL-ACTION BACKING PAD FOR MODEL 328</b>		
328B-825-8	8"	Standard-duty - pad assembly
<b>POLISHING PAD FOR MODELS 314, 318, OR ANY POLISHER WITH A 5/8"-11 SPINDLE</b>		
6135A	8"	2" thick polyester foam
<b>STRAIGHT LINE SANDING PAD FOR MODEL 315</b>		
315-39	N/A	Non-metallic material; fits similar brands of straight-line sanders

The full range of Ingersoll Rand sanding, backing, and polishing pads will help you complete every sanding, polishing, and grinding job to your satisfaction.

### 315-39 Straight-line Sanding Pads

For use with model 315. Non-metallic material reduces side strap wear caused by metallic sanding pads. Fits other similar brands of straight-line sanders.



### 6135A Polishing Pads

Polishing pads have 8" diameter, 2" thick polyester foam. For use with models 314, 318, or any polisher with a 5/8"-11 spindle.

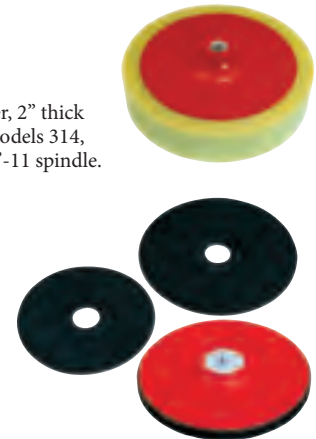



# Air Drills and Screwdrivers



Ingersoll Rand air drills have industrial-grade chucks and keyless chuck versions that are extra-tough for drilling, sawing, valve guide reaming, cylinder honing, and wire brushing. They are powerful, efficient, and durable with smooth, quiet operation.



## Air Drills and Screwdrivers

Model	Chuck Size in (mm)	Free Speed rpm	Rated Power hp (kW)	Net Weight lb (kg)	Overall Length in (mm)	Average Air Consumption cfm (L/min)	Air Consumption @ Load cfm (L/min)	Sound Pressure / Power dBA	Air Inlet NPTF in	Min Hose Size in (mm)
<b>3/8" CHUCK DRILL</b>										
7802A	3/8" (10)	2,000	0.5 (0.38)	2.6 (1.1)	7.8" (198)	4 (113)	26 (736)	83 / 94	1/4"	3/8" (10)
7802RA	3/8" (10)	2,000	0.5 (0.38)	2.9 (1.2)	7.8" (198)	4 (113)	26 (736)	82 / 93	1/4"	3/8" (10)
7802RAKC	3/8" (10)	2,000	0.5 (0.38)	2.9 (1.2)	7.4" (188)	4 (113)	26 (736)	82 / 93	1/4"	3/8" (10)
<b>1/2" CHUCK DRILL</b>										
7803A	1/2" (13)	500	0.5 (0.38)	3.2 (1.45)	9" (229)	4 (113)	27 (765)	83 / 94	1/4"	3/8" (10)
7803RA*	1/2" (13)	500	0.5 (0.38)	3.3 (1.5)	8.7" (221)	4 (113)	27 (765)	83 / 94	1/4"	3/8" (10)
7803RAKC*	1/2" (13)	500	0.5 (0.38)	3.3 (1.5)	8.7" (221)	4 (113)	27 (765)	83 / 94	1/4"	3/8" (10)

\*Not pictured.

### 7802A

#### Air Drill

With its industrial-grade 3/8" chuck, this economical choice includes high-quality features for general drilling and hole-sawing jobs. The planetary gear reduction balances the load on bearings and gears for increased tool life.

- Variable speed throttle
- Lightweight, compact drill

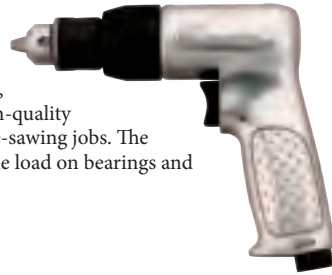

### 7802RA

#### Reversible Air Drill

Use this economical, high-quality 3/8" drill for all your general purpose drilling, honing, reaming, and hole-sawing. With its reversible 0.5 hp motor, you can also drive and remove screws — including backing out tight screws without a struggle.

- Reversible motor with a quick reverse lever
- Variable speed throttle for starting holes easily
- Smooth, lightweight, compact drill



### 7802RAKC

#### Reversible Air Drill / Keyless Chuck

With its industrial-grade 3/8" chuck, this economical choice includes high-quality features for general drilling and hole-sawing jobs. The planetary gear reduction balances the load on bearings and gears for increased tool life.

- Variable speed throttle
- Lightweight, compact drill
- Keyless chuck



### 7803A

#### Air Drill

Here's the economical choice for power — a high-quality air drill designed for drilling, hole-sawing, cylinder honing, and any other job that calls for a 1/2" size. Its quality features for long life include the industrial-grade 1/2" chuck, ball and needle bearing construction, and double-reduction planetary gearing.

- No-load speed of 500 rpm
- Auxiliary side handle



## Drill Bits

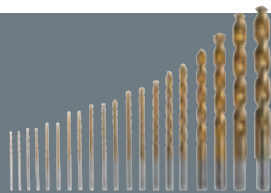

No matter what your drilling needs may be, count on Ingersoll Rand for the bits required to get the job done. Our line of bits can be found on page 61-63.

Model	Free Speed rpm	Chuck Size in (mm)	Rated Power hp (kW)	Net Weight lb (kg)	Overall Length in (mm)	Average Air Consumption cfm (L/min)	Air Consumption @ Load cfm (L/min)	Sound Pressure / Power dBA	Air Inlet NPTF in	Min Hose Size in (mm)
<b>1/4" MINI TOOL DRILL / DRIVER</b>										
7804XP	1,600	1/4"	N/A	1.7 (0.78)	7.3" (184)	1.9 (54)	17.5 (495)	83.6 / 94.6	1/4"	3/8" (10)
<b>3/8" CHUCK — RIGHT ANGLE DRILL</b>										
7807R	1,800	3/8" (10)	0.33 (0.25)	2.4 (1.13)	8.1" (206)	4 (113)	17 (481)	89 / 102	1/4"	3/8" (10)
<b>1/4" CHUCK SCREWDRIVER</b>										
371	1,800	1/4" hex	0.44 (0.33)	2.5 (1.15)	7.4" (188)	4 (113)	29 (821)	78 / 91	1/4"	3/8" (10)

## 7804XP

### 1/4" Mini Drill / Driver

- Double-sided, adjustable speed settings provide variability for a broader range of applications
- Double-bearing construction for longer life, impressive balance, and reduced vibration
- Reversible motor control



**Hard-hitting 5-vane motor delivers smooth and robust performance**

## 7804K

### 1/4" Mini Drill / Driver Kit

- Includes 22-piece drill bit and driver set



## 7807R

### 3/8" Angle Reversible Drill

The 7807R is an excellent choice for service work requiring a compact, low-profile angle head. It's a durable, reliable tool for drilling in all types of materials, including sheet metal, wood, and composites.

- Durable Jacobs multi-craft chuck
- Reversible, with convenient control
- Precision machine gearing ensures maximum power transfer and durability



## 371

### Reversible Pistol-grip Screwdriver

The 371 is an excellent choice for soft-draw applications. This tool is well-suited for service work on HVAC systems, instrument panels, and trim components. It delivers reliable performance for driving sheet metal, self-tapping, and wood screws.

- Positive action clutch, for full torque throughout rundown
- Convenient one-handed operation, with reverse control at trigger
- Variable speed throttle for easy starts



## Replacement Chucks and Chuck Keys

Model	Capacity in (mm)	Thread in (mm)	Chuck Key Catalog Number	Tool Number
728-99-KC5	3/8" (10)	3/8" x 24" (10 x 610)	Keyless	7802, 7802R, 7811
728-99-KC8	1/2" (13)	3/8" x 24" (10 x 610)	Keyless	7806, 7803, 7803R, 7816R
7803-99	1/2" (13)	3/8" x 24" (10 x 610)	7803-253	7803, 7803R, 7816R



## Drill Boots

Part Number	Description	For Use With
<b>PROTECTIVE TOOL BOOTS</b>		
7802-BOOT	Air drill boot with Ingersoll Rand logo printed on red boot	7802A, 7802RA, 7802RAKC
7803-BOOT	Air drill boot with Ingersoll Rand logo printed on red boot	7803A, 7803RA, 7803RAKC

## Drill/Hex Bits

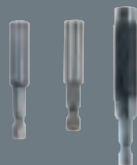

No matter what your drilling needs may be, count on Ingersoll Rand for the bits required to get the job done. We offer a variety of drill bits and hex driver bits designed specifically for our cordless drills/drivers. See pages 61-63.

# Air Hammers



Ingersoll Rand air hammers are designed so you can let the tool do the work, whether it's cutting, punching, chipping, or scraping. Each air hammer comes with a coil spring retainer for fast and easy chisel changes. You can also buy a five-piece chisel set, or get an Ingersoll Rand air hammer kit, which includes both the hammer and the chisel set.



## Air Hammers

Model	Shank Opening in (mm)	bpm @ 90 psi	Bore Diameter in (mm)	Stroke Length in (mm)	Weight lb (kg)	Length in (mm)	Average Air Consumption cfm (L/min)	Air Consumption @ Load cfm (L/min)	Sound Pressure / Power dBA	Air Inlet NPTF in	Min Hose Size in (mm)
115	0.401" (10.1)	5,000	0.75" (19)	1.63" (41)	2.6 (1.18)	6.1" (155)	2 (57)	14 (396)	101.3 / 114.3	1/4"	3/8" (10)
115K*	0.401" (10.1)	5,000	0.75" (19)	1.63" (41)	2.6 (1.18)	6.1" (155)	2 (57)	14 (396)	101.3 / 114.3	1/4"	3/8" (10)
116	0.401" (10.1)	3,500	0.69" (17.5)	2.63" (67)	3.4 (1.54)	7.8" (198)	3 (85)	15 (425)	104.4 / 117.4	1/4"	3/8" (10)
116K*	0.401" (10.1)	3,500	0.69" (17.5)	2.63" (67)	3.4 (1.54)	7.8" (198)	3 (85)	15 (425)	104.4 / 117.4	1/4"	3/8" (10)
117	0.401" (10.1)	2,000	0.69" (17.5)	3.5" (89)	4.1 (1.86)	9.9" (251)	3 (85)	14 (396)	103.5 / 116.5	1/4"	3/8" (10)
117K*	0.401" (10.1)	2,000	0.69" (17.5)	3.5" (89)	4.1 (1.86)	9.9" (251)	3 (85)	14 (396)	103.5 / 116.5	1/4"	3/8" (10)
121-K6	0.401" (10.1)	3,000	0.75" (19)	2.28" (58)	3.5 (1.59)	7.6" (194)	3 (85)	15 (425)	98.3 / 111.3	1/4"	3/8" (10)
121/Q*	0.401" (10.1)	3,000	0.75" (19)	2.28" (58)	3.5 (1.59)	7.6" (194)	3 (85)	15 (425)	98.3 / 111.3	1/4"	3/8" (10)
132*	0.401" (10.1)	1,725	0.56" (14)	4.00" (102)	3.4 (1.54)	8.5" (216)	3 (85)	11 (311)	N/A	1/4"	5/16" (8)

\*Not pictured.

### 115

#### Air Hammer

This powerful yet economical high-speed air hammer is designed for light exhaust system work and general cutting, chipping, and scraping.

- Up to 5,000 blows per minute
- Alloyed steel barrel and heat-treated piston for longer life
- Built-in power regulator and trigger control

Also available: 115K includes 5-piece chisel kit.



### 116

#### Air Hammer

The economical air hammer for fast cutting action, especially for medium exhaust system, panel cutting, and general repair work.

- Up to 3,500 blows per minute
- Handles a range of cutting applications
- Longer-life alloyed steel barrel and heat-treated piston

Also available: 116K includes 5-piece chisel kit.



### 117

#### Air Hammer

An economical air hammer with a longer piston stroke, this tool is designed for exhaust work, bolt cutting, and front-end work. The trigger control and a built-in power regulator give you full control of the speed and power.

- Longer-stroke piston
- Alloyed steel barrel and heat-treated piston for longer life
- Up to 2,000 blows per minute

Also available: 117K includes 5-piece chisel kit.

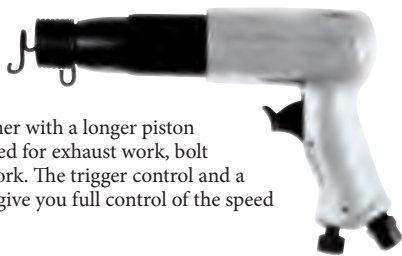

### 121-K6

#### Air Hammer Kit

Make fast work of body panel crimping and cutting, bushing, driving, shearing, and general front-end work with this air hammer.

- 3,000 blows per minute
- Tough 1-piece alloy barrel
- Kit includes blow-molded case and 6-piece chisel set

Also available: 121/Q tool only.



## 9500 Chisel Set

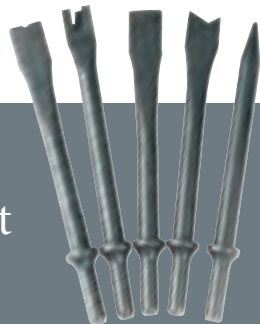

A five-piece chisel set in a plastic pouch with 0.401" shank diameters to match your Ingersoll Rand air hammer. See page 47 for more information about this set and all our other chisels.

## Needle and Chisel Scaler

Model	Needle Quantity	Needle Size in (mm)	bpm @ Free Speed rpm	Bore Diameter in (mm)	Stroke Length in (mm)	Weight lb (kg)	Length in (mm)	Average Air Consumption cfm (L/min)	Air Consumption @ Load cfm (L/min)	Sound Pressure / Power dBA	Air Inlet NPTF in	Min Hose Size in (mm)
125	19	1/8" (3.2)	4,600	1" (25)	1.1" (28.6)	6.2 (2.8)	18.3" (465)	8 (226)	15 (425)	99.6 / 112.6	1/4"	5/16" (8)
125CI*	N/A	N/A	4,600	1" (25)	1.1" (28.6)	4.1 (1.9)	11.4" (289)	8 (226)	15 (425)	99.6 / 112.6	1/4"	5/16" (8)

\*Not pictured.

### 125

#### Needle Scaler

For surface preparation work involving the cleaning or removal of paint, rust, dirt, or weld slag, the 125 is a durable, dependable, and economical solution.

- 19 needles
- Each needle diameter measures 1/8"
- 4,600 blows per minute at free speed



### 125 Chisels

Model	Type	Width* in (mm)
WF-14B-007	Wide Chisel	1-3/8" (35)
WF-14A-007	Spoon Chisel	1-3/8" (35)
WF-14C-008	Wide Chisel	2" (50)
WF-14D-008	Wide Chisel	3" (75)
PF2200-3231	Round nose	1/4" (6)
PF2200-3232	Cape chisel	1/4" (6)

\*All chisels are 7" in length.

### 125CI

#### Chisel Scaler

Same great features as the 125 only instead of needles, tool uses a chisel.

## Replacement Needle Set

Part Number	Description	Width* in (mm)
PF2219-22-19	Needle set	1/8" (3)

\*All chisels are 7" in length.

## Spring Retainers

Model	Description	For Use With
115-183	Spring retainer	115, 116, 117
AVC10-183A	Spring retainer	121, 132
AVC1-83	Beehive retainer	121, 132

## Replacement Chisels

Model	Description
9500	5-piece hammer chisel set
9505	Hammer spring retainer, 2 pack
9512	Quick change hammer retainer for 121, 132, 115, 116, 117
950011	Tailpipe cut-off tool
950012	Slotted panel cutter
950013	Rivet and bolt cutter
950014	Pneumatic scraper
950015	Pneumatic hammer chisel
950016	Pneumatic cold chisel, 8"
950017	Pneumatic cold chisel
950018	Muffler and tailpipe remover
950019	Pneumatic ball joint separator

# Mini Air Tools



Our mini tools range in size between 5" and 7-1/4" in length, making them small enough to easily fit in the palm of almost anyone's hand, and ideal for tight spaces and fine detail finish work. They perfectly complement our existing lineup of full-size automotive maintenance and repair tools — delivering the power, versatility, and durability that you have come to expect from Ingersoll Rand.

The mini tools feature composite housings with ergonomic textured grips to provide comfort and exceptional resistance to grease, chemicals, and extreme temperatures. They also feature lightweight, pistol-grip designs with thumb-actuated switches engineered for balance and one-handed operation, variable-speed triggers, and a complete accessory package.



## Mini Tools

### 2101XP Specifications

Drive - in	1/4"
Torque Range (forward) - ft-lb (Nm)	25 - 40 (34 - 54)
Max Torque (reverse) - ft-lb (Nm)	50 (68)
Free Speed - rpm	11,000
Blows Per Minute - bpm	1,250
Standard Bolt Capacity - in	5/16"
Net Weight - lb (kg)	1.4 (0.6)
Kit Weight - lb (kg)	3 (1.4)
Overall Length - in (mm)	6.3 (160)
Average Air Consumption - cfm	1.8
@ Load - cfm	18.2
Sound (pressure / power) - dBA	81.8/92.8
Air Inlet - in	1/4"
Min Hose Size - in	3/8"



### 2101XP

#### 1/4" Mini Impactool

- Powerful impact mechanism is engineered to deliver 45 ft-lb (61 Nm) of torque (forward) where you need it most
- Hard-hitting five-vane motor delivers smooth and robust performance
- Easily accessible forward / reverse switch for one-handed operation

### 2101XP-QC Specifications

Drive - in	1/4"
Torque Range (forward) - ft-lb (Nm)	25 - 40 (34 - 54)
Max Torque (reverse) - ft-lb (Nm)	50 (68)
Free Speed - rpm	11,000
Blows Per Minute - bpm	1,250
Standard Bolt Capacity - in	5/16"
Net Weight - lb (kg)	1.4 (0.7)
Kit Weight - lb (kg)	3 (1.4)
Overall Length - in (mm)	6.8 (173)
Average Air Consumption - cfm	1.8
@ Load - cfm	18.2
Sound (pressure / power) - dBA	81.8/92.8
Air Inlet - in	1/4"
Min Hose Size - in	3/8"



### 2101XP-QC

#### 1/4" Quick Change Mini Impactool

- Powerful impact mechanism is engineered to deliver 45 ft-lbs. (61 Nm) of torque (forward) where you need it most
- Hard-hitting 5-vane motor delivers smooth and robust performance
- Easily accessible forward/reverse switch for one-handed operation
- Quick change feature allows for simple and convenient attachment exchange

### 2102XP Specifications

Drive - in	3/8"
Torque Range (forward) - ft-lb (Nm)	25 - 40 (34 - 54)
Max Torque (reverse) - ft-lb (Nm)	50 (68)
Free Speed - rpm	11,000
Blows Per Minute - bpm	1,250
Standard Bolt Capacity - in	5/16"
Net Weight - lb (kg)	1.4 (0.6)
Kit Weight - lb (kg)	3 (1.4)
Overall Length - in (mm)	6.3 (160)
Average Air Consumption - cfm	1.8
@ Load - cfm	18.2
Sound (pressure / power) - dBA	81.8/92.8
Air Inlet - in	1/4"
Min Hose Size - in	3/8"



### 2102XP

#### 3/8" Mini Impactool

- Powerful impact mechanism is engineered to deliver 45 ft-lbs. (61 Nm) of torque (forward) where you need it most
- Hard-hitting 5-vane motor delivers smooth and robust performance
- Easily accessible forward/reverse switch for one-handed operation
- Ideal for those hard-to-reach places where conventional tools cant go

## Mini Tools

### 7804XP Specifications

Drive - in	1/4"
Torque - ft-lbs (Nm)	1.1 (1.5)
Free Speed - rpm	1,600
Net Weight - lb (kg)	1.7 (0.8)
Kit Weight - lb (kg)	2.7 (1.2)
Overall Length - in (mm)	7.3 (185)
Average Air Consumption - cfm	1.9
@ Load - cfm	17.5
Sound (pressure / power) - dBA	83.6/94.6
Air Inlet - in	1/4"
Min Hose Size - in	3/8"



### 7804XP

1/4" Mini Drill/Driver

- Hard-hitting five-vane motor delivers smooth and robust performance
- Double-sided, adjustable speed settings provide variability for a broader range of applications
- Double-bearing construction for longer life, impressive balance, and reduced vibration
- Reversible motor control

### 3103XP Specifications

Drive - in	1/4"
Free Speed - rpm	15,000
Rated Power - hp	0.2
Net Weight - lb (kg)	1.0 (0.5)
Kit Weight - lb (kg)	2.7 (1.2)
Overall Length - in (mm)	5 (127)
Average Air Consumption - cfm	2.1
@ Load - cfm	19.4
Sound (pressure / power) - dBA	84.9/95.9
Air Inlet - in	1/4"
Min Hose Size - in	3/8"



### 3103XP

Mini Surface Prep Sander

- Ideal for the removal of rust, surface deposits, and welds in hard-to-reach areas
- Ball-bearing construction enhances durability and smooth power delivery
- Includes 2" and 3" medium backing pads

### 3128XP Specifications

Pad Size - in (mm)	3" (75)
Free Speed - rpm	15,000
Rated Power - hp	0.2
Net Weight - lb (kg)	1.1 (0.5)
Kit Weight - lb (kg)	2.8 (1.3)
Overall Length - in (mm)	5.5 (140)
Average Air Consumption - cfm	2.1
@ Load - cfm	14.7
Sound (pressure / power) - dBA	84.2/96.9
Air Inlet - in	1/4"
Min Hose Size - in	3/8"



### 3128XP

Mini Random Orbital Sander

- Engineered for the most aggressive sanding applications
- Delivers swirl-free finishes when feather edging, removing rust, preparing metal surfaces, or smoothing welds
- Durable ball-bearing construction ensures smooth power delivery
- Includes 3" hook & loop style backing pad

### 3129K Specifications

Pad Size - in (mm)	3" (75)
Free Speed - rpm	6,000
Rated Power - hp	0.3
Net Weight - lb (kg)	1.3 (0.6)
Kit Weight - lb (kg)	2.9 (1.3)
Overall Length - in (mm)	6" (152)
Average Air Consumption - cfm	2.2
@ Load - cfm	19.9
Sound (pressure / power) - dBA	83.5/94.85
Air Inlet - in	1/4"
Min Hose Size - in	3/8"



### 3129XP

Mini Polisher

- Ideal for buffing and polishing paint, metal, and plastic surfaces to a highgloss finish
- Free speed of 6,000 rpm delivers the same performance of polishers twice the size
- Double-sided, adjustable speed settings provide variability for a broader range of applications
- Includes 3" hook & loop style backing pad

## Mini Tool Kits

### 2101K

#### Mini 1/4" Impactool Kit



Kit Includes 2101XP and 10-piece 1/4" socket set

### 7804K

#### Mini 1/4" Drill/Driver Kit



Kit Includes 7804XP and 22-piece drill bit and driver set

### 3103K

#### Mini Surface Prep Sander Kit



Kit Includes 3103XP and 14-piece 2" and 3" sanding discs

### 3128K

#### Mini Random Orbital Sander Kit



Kit Includes 3128XP and 71-piece hook & loop discs

### 3129K

#### Mini Polisher Kit



Kit Includes 3129XP and 4-piece hook & loop pads

## Mini Tool Accessories

Part Number	Description
<b>MINI POLISHER ACCESSORIES</b>	
03H-PAD-HL	3" hook-and-loop backer pad (fits polisher and RO sander)
03F-SFTWL-6	3" hook-and-loop wool pad (for compounding)
03F-MEDFM-6	3" hook-and-loop waffle pad white (for compounding)
03F-SFTFM-6	3" hook-and-loop waffle pad yellow (for polishing)



3" hook-and-loop backer pad



3" hook-and-loop wool pad



3" hook-and-loop waffle pad, white



3" hook-and-loop waffle pad, yellow



6-piece box as shown

Part Number	Description	Grit
<b>3" HOOK AND LOOP AO PAPER</b>		
03H-040AO-50	3" hook-and-loop aluminum oxide disc	40
03H-080AO-50	3" hook-and-loop aluminum oxide disc	80
03H-100AO-50	3" hook-and-loop aluminum oxide disc	100
03H-120AO-50	3" hook-and-loop aluminum oxide disc	120
03H-180AO-50	3" hook-and-loop aluminum oxide disc	180
03H-220AO-50	3" hook-and-loop aluminum oxide disc	220
03H-240AO-50	3" hook-and-loop aluminum oxide disc	240
03H-320AO-50	3" hook-and-loop aluminum oxide disc	320
03H-360AO-50	3" hook-and-loop aluminum oxide disc	360
03H-400AO-50	3" hook-and-loop aluminum oxide disc	400
03H-500AO-50	3" hook-and-loop aluminum oxide disc	500
03H-800AO-50	3" hook-and-loop aluminum oxide disc	800



50-piece box as shown

# IQ<sup>V</sup>™ Series Cordless Tools

Specifically designed for the service and production industries, Ingersoll Rand IQ<sup>V</sup>™ Series cordless tools deliver best-in-class power and durability, and are backed by our strong commitment to our customers. The same engineering that made our air tools the world's best now delivers cordless technologies that get the most out of every volt. We offer the revolutionary IQ<sup>v</sup> lithium-ion battery in three voltage platforms suited to a variety of applications. The IQ<sup>V</sup> Series is also backed by the best warranty in the industry.

# More than just cordless, *Ingersoll Rand* cordless

- First line of cordless tools specifically designed for the professional mechanic
- Delivers unmatched power, durability, and our commitment to enhance your productivity and satisfaction



### Industry-leading durability

- Rugged internal mechanisms last up to five times longer than competition
- Metal-reinforced housings add strength for unmatched drop resistance
- Engineered composite housings for increased resistance against corrosive chemicals
- Built to hit hard — and take a beating — for years



### IQV Grip batteries

- Patented twist-to-lock battery connection
- Eliminates wear and tear common with competitive battery mounts



### Smart voltage

- Integrated microprocessor circuitry delivers optimized charging and power



### Intelligent charging

- IQV charger works with all voltages of our lithium-ion batteries
- Automatically detects battery chemistry and voltage to optimize charging
- Extends recharge life — up to three times longer than the competition

## IQV™ WARRANTY

**1 Year**  
Hassle-Free  
Tool & Charger  
Replacement

**2 Year**  
or 1,000  
Recharges  
Battery Limited Warranty

**3 Year**  
Limited Warranty  
Tools & Chargers  
3 year does not include  
saws, grinders and  
cut-off tools

REGISTRATION REQUIRED (irtools.com)  
See irtools.com for Official Terms & Conditions  
May vary by tool and country



## Cordless Impacttools

Model	Drive Size	Drive Type	Max Torque ft-lb (Nm)	Usable Torque Range ft-lb (Nm)	Speed rpm	Impacts per minute	Weight Tool Only lb (kg)	Tool w/Battery lb (kg)	Length in (cm)	Sound Pressure / Power dBA	Voltage volts
W040	1/4"	Quick change	40 (54)	1 – 32 (2 – 43)	0-2,200	0-2,500	1.8 (0.8)	2.7 (1.2)	7 (17.8)	83.8 / 94.8	7.2
W040SQ*	3/8"	Square	40 (54)	1 – 32 (2 – 43)	0-2,200	0-2,500	1.8 (0.8)	2.7 (1.2)	7 (17.8)	83.8 / 94.8	7.2
W040P*	3/8"	Square pin	40 (54)	1 – 32 (2 – 43)	0-2,200	0-2,500	1.8 (0.8)	2.7 (1.2)	7 (17.8)	83.8 / 94.8	7.2
W150	3/8"	Square	150 (203)	25 – 130 (34 – 176)	0-2,200	0-3,000	3.2 (1.5)	4.7 (2.1)	8.2 (20.9)	90.8 / 101.8	14.4
W150QC*	1/4"	Quick change	150 (203)	25 – 130 (34 – 176)	0-2,200	0-3,000	3.2 (1.5)	4.7 (2.1)	8.2 (20.9)	90.8 / 101.8	14.4
W150P*	3/8"	Square pin	150 (203)	25 – 130 (34 – 176)	0-2,200	0-3,000	3.2 (1.5)	4.7 (2.1)	8.2 (20.9)	90.8 / 101.8	14.4
W175*	1/2"	Square	175 (237)	25 – 130 (34 – 176)	0-2,200	0-3,000	3.2 (1.5)	4.7 (2.1)	8.2 (20.9)	90.8 / 101.8	14.4
W175P*	1/2"	Square pin	175 (237)	25 – 130 (34 – 176)	0-2,200	0-3,000	3.2 (1.5)	4.7 (2.1)	8.2 (20.9)	90.8 / 101.8	14.4
W360	1/2"	Square	360 (488)	25 – 280 (33 – 379)	0-1,650	0-2,200	4.8 (2.2)	6.2 (2.8)	9 (22.8)	92.3 / 103.3	19.2
W360P*	1/2"	Square pin	360 (488)	25 – 280 (33 – 379)	0-1,650	0-2,200	4.8 (2.2)	6.2 (2.8)	9 (22.8)	92.3 / 103.3	19.2
W360-2*	1/2"	Square 2" extension	360 (488)	25 – 280 (33 – 379)	0-1,650	0-2,200	4.8 (2.2)	6.2 (2.8)	9 (22.8)	92.3 / 103.3	19.2

\*Not pictured.

Batteries and chargers sold separately.

### W040

#### QC 1/4" Cordless Impacttool

With its 40 ft-lb of maximum reverse torque, the W040 delivers the right amount of power for tasks involving small fasteners. Its industrial-grade quick change hex lets you change bits easily and enables bind-free operation.

- Compact for easy access in confined spaces
- 40 ft-lb maximum reverse torque
- Lightweight — only 2.7 lb with lithium-ion battery



### W150

#### 3/8" Cordless Impacttool\*

An optimized impact mechanism enables the W150 to deliver 150 ft-lb of maximum reverse torque with only 14.4 volts. Like its counterpart, the W360, this Impacttool features a steel-reinforced frame where tools are most vulnerable to drop damage.

- Industrial-grade durability
- 150 ft-lb maximum reverse torque
- Lightweight — only 4.7 lb with lithium-ion battery

\*Sockets and drill bits not included.



Cordless Power Tools

### W360

#### 1/2" Cordless Impacttool

It's hard to believe the W360 is a cordless tool. At 360 ft-lb of maximum reverse torque, the W360 produces more power with less voltage, size, and weight than competitive models.

- Class leading power-to-weight ratio
- 360 ft-lb maximum reverse torque
- Lightweight — only 6.2 lb with lithium-ion battery



## Cordless Boots







Our IQ<sup>V</sup> Series cordless tool boots absorb vibrations and protect the tool from dirt, grime, wear and tear, and accidental external damage. Our boots can be found on pages 64. For our complete line of accessories see our Accessory Catalog (IRITS-0810-069)

## IQ<sup>V</sup> Series Cordless Kits

Top-selling Ingersoll Rand cordless tools are now available in convenient hard case kits for a quick and easy way to start your new IQ<sup>V</sup> cordless tool collection. Individual tools, batteries, chargers, and accessories are available for purchase through our IQ<sup>V</sup> Choice program — offering a cost-effective way to expand or upgrade your IQ<sup>V</sup> tool collection later on.



IMPACTTOOLS™	DESCRIPTION	Kit Includes*	
		1 Battery	2 Batteries
		MODELS	
	1/4" 7.2V Impact Driver Kit with Li-Ion battery, charger and case	W040-KL1	W040-KL2
	3/8" 14.4V Impact Wrench Kit with Li-Ion battery, charger and case	W150-KL1	W150-KL2
	1/2" 19.2V Impact Wrench Kit with 1 Li-Ion battery, charger and case	W360-KL1	W360-KL2
	3/8" Pin-Type 14.4V Impact Wrench Kit with 2 Li-Ion Batteries, charger and case	N/A	W150P-KL2
RATCHETS	DESCRIPTION	MODELS	
	1/4" 7.2V Ratchet Kit with Li-Ion battery, charger and case	R140-KL1	R140-KL2
	3/8" 7.2V Ratchet Kit with Li-Ion battery, charger and case	R145-KL1	R145-KL2
	3/8" 14.4V Ratchet Kit with Li-Ion battery, charger and case	R380-KL1	R380-KL2
	1/2" 14.4V Ratchet Kit with 1 Li-Ion battery, charger and case	R385-KL1	R385-KL2
DRILLS	DESCRIPTION	MODELS	
	1/4" Keyed Chuck 7.2V Drill/Driver Kit with Li-Ion battery, charger and case	D040-KL1	D040-KL2
	1/2" Keyless Chuck 14.4V Drill/Driver Kit with Li-Ion battery, charger and case	D550S-KL1	D550S-KL2
	1/2" Keyless Chuck 19.2V Drill/Driver Kit with Li-Ion battery, charger and case	D650S-KL1	D650S-KL2
GRINDERS	DESCRIPTION	MODELS	
	14.4V Straight Die Grinder Kit with Li-Ion battery, charger and case	GS25-KL1	GS25-KL2
	14.4V Right Angle Grinder Kit with Li-Ion battery, charger and case	GR25-KL1	GR25-KL2
	14.4V Cutoff Tool Grinder Kit with Li-Ion battery, charger and case	GC25-KL1	GC25-KL2

\*All kits include universal charger (7.2V - 19.2V)



## Cordless Drill Drivers

Model	Ideal Stall Torque in-lb (Nm)	Speed rpm	Weight - Tool Only lb (kg)	Tool w/ Battery lb (kg)	Length in (cm)	Sound Pressure / Power dBA	Voltage volts
D040	40 (4.5)	0 - 1,100	1.7 (.77)	2.5 (1.1)	6.9 (17.6)	63.4 / 74.4	7.2
D550S	550 (62)	0 - 360 / 0 - 1,300	3.3 (1.5)	4.6 (2.1)	9.2 (23.3)	76.1 / 87.1	14.4
D650S	650 (73)	0 - 360 / 0 - 1,300	3.3 (1.5)	4.8 (2.2)	9.2 (23.3)	70.8 / 81.8	19.2

Sold separately: BC20 battery charger; BL144 Li-Ion (for D550S); BL192 Li-Ion (for D650S).

### D040

#### 1/4" Mini Drill

The D040 1/4" mini drill is the perfect solution for all of your tight access drilling applications. Under 7" long, this tool can fit into even the smallest areas with ease. The 1/4" keyed chuck ensures bit retention and more reliable performance. Weighing only 2.5 lb, the D040 is extremely ergonomic and ideal for drilling small holes and screwdriving.

- Smallest and lightest cordless drill in its class
- Variable speed trigger ensures maximum control and higher motor durability
- Drop-resistant structural housing protects against breakage



### D550S

#### Cordless Drill / Driver

The D550S and D650S offer 550 and 650 in-lbs of torque respectively, providing maximum productivity and durability for professional end users in a wide range of drilling and fastening applications. Industrial grade features allow for easy and secure one-handed bit insertion, tightening and removal. Two-speed all metal gear train provides superior power and durability.

- Automatic spindle lock
- Composite housing with metal sub-frame
- Variable speed trigger



### D650S

#### Cordless Drill / Driver

The D550S and D650S offer 550 and 650 in-lbs of torque respectively, providing maximum productivity and durability for professional end users in a wide range of drilling and fastening applications. Industrial grade features allow for easy and secure one-handed bit insertion, tightening and removal. Two-speed all metal gear train provides superior power and durability.

- Automatic spindle lock
- Composite housing with metal sub-frame
- Variable speed trigger



## Drill Bits

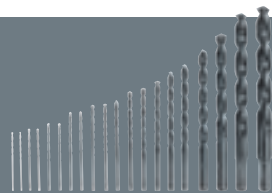

We offer a variety of drill bits and hex driver bits designed specifically for our cordless drills/drivers. Our line of cordless accessories can be found on pages 61 – 64. For our complete line of accessories see our Accessory Catalog (IRITS-0810-069)

## Cordless Ratchets

Model	Type	Anvil Size in	Voltage volts	Useable Torque Range ft-lb (Nm)	Max Torque ft-lb (Nm)	Free Speed rpm	Weight – Tool Only lb (kg)	Tool w/ Battery lb (kg)	Length in (mm)	Switch Type	Sound Pressure / Power dBA
R140	Mini	1/4"	7.2	5 – 25 (7 – 34)	25 (34)	225	2.0 (0.9)	2.9 (1.3)	10.7 (272)	Variable speed	74.9 / 85.9
R145*	Mini	3/8"	7.2	5 – 25 (7 – 34)	25 (34)	225	2.0 (0.9)	2.9 (1.3)	10.7 (272)	Variable speed	74.9 / 85.9
R380	Standard	3/8"	14.4	10 – 60 (14 – 81)	70 (94)	225	2.8 (1.3)	4.3 (1.9)	12.4 (315)	Variable speed	80.8 / 91.8
R385*	Standard	1/2"	14.4	10 – 60 (14 – 81)	70 (94)	225	2.8 (1.3)	4.3 (1.9)	12.4 (315)	Variable speed	80.8 / 91.8

\*Not pictured

Sold separately: BC20 battery charger; BL144 Li-Ion battery

### R140

#### Cordless 1/4" Mini Ratchet

Delivers impressive performance for its size — a mere 2.9 lb with a lithium-ion battery.

- 25 ft-lb of maximum torque
- Impressive mobility for hard-to-reach tasks
- Compatible with all 7.2-volt IQ<sup>V</sup> lithium-ion



### R380

#### Cordless 3/8" Standard Ratchet

Delivers the perfect combination of power, durability, and convenience. At 70 ft-lb maximum torque, the R380 is more powerful than any other ratchet in its class.

- Advanced head design — built with the proven 107XPA pneumatic ratchet head
- Proprietary motor control with variable speed
- Compatible with all 14.4-volt IQ<sup>V</sup> batteries including lithium-ion



## Cordless Grinders

Model	Type	Collet Size in	Power hp	Free Speed rpm	Voltage volts	Weight – Tool Only lb (kg)	Tool w/ Battery lb (kg)	Length in (mm)	Switch Type	Sound Pressure / Power dBA
GS25	Straight	1/4"	0.35	27,500	14.4	1.5 (0.67)	2.9 (1.4)	9 (230)	Variable speed	70.4/81.4
GR25	Right angle	1/4"	0.35	20,000	14.4	1.8 (0.82)	3.3 (1.5)	9.5 (240)	Variable speed	72.5/83.5

Sold separately: BC20 battery charger; BL144 Li-Ion battery

### GS25

#### Cordless Straight Grinder

Versatility without a cord or hose, 0.35 hp motor, battery compatibility, variable speed, and an exclusive motor control that prevents motor damage from heat or stalling.

- 27,500 rpm free speed
- Same proven head and collet as our 3102 pneumatic die grinder
- 2.9 lb with lithium-ion battery



### GR25

#### Cordless Angle Grinder

Outstanding performance and portability for light-duty grinding. For use with accessories up to 2".

- 0.35 hp motor delivers impressive power
- Same proven angle head and collet as our 3102 pneumatic die grinder
- Compatible with all 14.4-volt IQ<sup>V</sup> batteries including lithium-ion



## Cut-off Tool

Model	Type	Collet Size in	Power hp	Free Speed rpm	Voltage volts	Weight - Tool Only lb (kg)	Tool w/ Battery lb (kg)	Length in (mm)	Switch Type	Sound Pressure / Power dBA
GC25	Cut-off	3"	0.35	25,000	14.4	1.8 (0.82)	3.1 (1.4)	9.5 (242)	Variable speed	72.5/83.5

Sold separately: BC20 battery charger; BL144 Li-Ion battery

### GC25

#### 3" Cut-off Tool

The GC25 3" cut-off tool combines power, durability, and portability to make one of the most versatile tools in your box. The only 3" cordless cut-off tool available, the GC25 is perfect for light-duty cutting jobs including muffler work, bolt cutting, exhaust, and sheet metal work.

- Powerful 0.35 hp motor
- Variable speed trigger provides feather control
- Microprocessor-controlled motor protection



## Task Light

Model	19.2-volt Li-Ion Weight lb (kg)	Length in (mm)	19.2-volt Battery Runtime
TL10	2.3 (1.04)	8.3 (211)	10 hours

Sold separately: BL072, BL144, BL129 batteries



### TL10

#### High Intensity LED Task Light

The TL10 high intensity LED task light utilizes state-of-the-art LED technology to provide the highest quality, brightest light available. An onboard microprocessor allows the TL10 to work with all IQV batteries. The high-output LED bulb offers up to 50,000 hours of bulb life and up to 10 hours runtime (BL192).

- Works with all IQV batteries
- 160° pivoting, low-profile head provides lighting versatility
- High-quality 4-watt LED bulb lasts up to 50,000 hours

## IQV™ WARRANTY

<h1 style="font-size: 2em;">1 Year</h1> <p>Hassle-Free Tool &amp; Charger Replacement</p>	<h1 style="font-size: 2em;">2 Year</h1> <p>or 1,000 Recharges Battery Limited Warranty</p>	<h1 style="font-size: 2em;">3 Year</h1> <p>Limited Warranty Tools &amp; Chargers <small>3 year does not include ratchets, grinders and cut-off tools</small></p>
---	--	--

REGISTRATION REQUIRED (irtools.com)  
See irtools.com for Official Terms & Conditions  
May vary by tool and country

Batteries sold separately.  
3-year warranty is not applicable for ratchets and grinders.

#### IQV Warranty

- 1-year hassle-free tool and charger replacement
- 2-year (or 1,000 recharges) battery limited warranty
- 3-year limited warranty tools and chargers

#### IQV Choice

- All tools sold individually — no more bulky combo kits
- Buy only what you need
- Flexibility to upgrade and expand
- Lowest long-term cost of ownership

#### Commitment to Cordless

- Full line of cordless tools

for service and production applications

- Distinctive products, designed for specific customer needs
- Complete line of Ingersoll Rand accessories optimized for our tools

Cordless Power Tools

## Cut-off Wheels

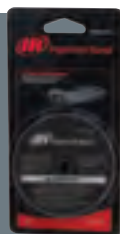

See page 34 for our Cut-off Wheels.

## Batteries, Chargers, and Accessories



### Batteries and Chargers

The revolutionary IQ<sup>V</sup> cordless power system features lithium-ion batteries — available in 7.2-volt, 14.4-volt, and 19.2-volt capacities. Our patented IQ<sup>V</sup> Grip twist-to-lock battery mount design eliminates wear and tear common to other types of mount clips and slides.

Our digitally controlled BC20 charger can be used with every one of our batteries. Once a battery is inserted into the charger, it automatically determines chemistry, voltage, and condition, thereby optimizing the charge process.



### Lithium-ion Batteries

Part Number	Description
BL072	7.2-volt battery
BL144	14.4-volt battery
BL192	19.2-volt battery

#### Features and Benefits

- Industry-leading lithium-ion cell technology blows the competition away with over 1,000 real recharges
- Patented twist-to-lock technology firmly holds battery in place — never duct tape your battery to your tool again!



### Battery Charger

Part Number	Description
BC20	Battery charger

#### Features and Benefits

- Allows the charger to charge BL072, BL144, BL192, N072, and N144 batteries
- Fully charges most batteries in less than 45 minutes

## Accessory Cases

Ingersoll Rand accessory cases are specifically designed to solve a number of common problems experienced by automotive and industrial professionals. These heavy-duty ballistic nylon cases are conveniently portable, easy to use, and can withstand the abuse any shop environment can dish out. The carriers are available in both book and flap styles.

- Feature magnetic buttons for one-handed bit access
- Metal-reinforced grommets for hanging
- Belt loops for greater mobility
- Unlike plastic cases, these won't damage sensitive work surfaces or break if dropped



## 1/4" Hex Bit Sets

Our quick change driver bits and related accessories are the perfect complement to our compact 1/4" cordless Impactool (all sets come in ballistic nylon accessory cases).

Part Number	Description
<b>HXNSK-10E</b>	<b>10-PIECE 2" POWER BIT SAE NUT SETTER KIT</b>
Sizes	5/32", 3/16", 7/32", 1/4", 9/32", 5/16", 11/32", 3/8", 7/16", 1/2"
Features	<ul style="list-style-type: none"> <li>• Quick-change hex drive for easy removal</li> <li>• Top of the line magnetics for increased bit retention</li> <li>• Full assortment of sizes to be used on any project</li> </ul>
<b>HXNSK-9M</b>	<b>9-PIECE 2" POWER BIT METRIC NUT SETTER KIT</b>
Sizes	5.5 mm, 6 mm, 7 mm, 8 mm, 9 mm, 10 mm, 11 mm, 12 mm, 13 mm
Features	<ul style="list-style-type: none"> <li>• Quick-change hex drive for quick and easy removal</li> <li>• Top of the line magnetics for increased bit retention</li> <li>• Full assortment of sizes to be used on any project</li> </ul>
<b>HXALK-9E</b>	<b>9-PIECE 2" MAGNETIC POWER BIT SAE ALLEN BIT KIT</b>
Sizes	1/16", 5/64", 3/32", 7/64", 1/8", 9/64", 5/32", 3/16", 1/4"
Features	<ul style="list-style-type: none"> <li>• Quick-change hex drive for quick and easy removal</li> <li>• Magnetic bit increases strength of hold on screw</li> <li>• Made of high-quality, industrial-grade steel</li> </ul>



## 1/4" Hex Bit Sets (continued)

Part Number	Description
<b>HXALK-9M</b>	<b>9-PIECE 2" MAGNETIC POWER BIT METRIC ALLEN BIT KIT</b>
Sizes	1.5 mm, 2 mm, 2.5 mm, 3 mm, 4 mm, 5 mm, 6 mm, 7 mm, 8 mm
Features	<ul style="list-style-type: none"> <li>• Quick-change hex drive for quick and easy removal</li> <li>• Magnetic bit increases strength of hold on screw</li> <li>• Made of high-quality, industrial-grade steel</li> </ul>
<b>HXSQS-2*</b>	<b>2-PIECE POWER BIT SOCKET ADAPTER SET</b>
Sizes	1/4" square drive adaptor, 3/8" square drive adaptor
Features	<ul style="list-style-type: none"> <li>• Allows addition of sockets to a driver</li> <li>• Magnetic tip allows for great hold on sockets</li> </ul>
<b>HXCMK-20</b>	<b>20-PIECE POWER BIT COMBO KIT</b>
Pieces	(2) #1 Phillips, #2 Phillips, #3 Phillips 5/32", 3/16", 1/4", 7/32" power Allen bits #6, #8, #10 slotted driver bits T8, T9, T10, T15, T20, T25, T30 Torx Res driver bits (2) #2 Phillips 3" long
Features	<ul style="list-style-type: none"> <li>• Assortment of bits for completion of all tasks</li> <li>• 3" Phillips bit for hard-to-reach places</li> <li>• Made of high-quality industrial-grade steel</li> </ul>
<b>HXCMK-30</b>	<b>30-PIECE POWER BIT COMBO KIT</b>
Pieces	(2) #1 Phillips, (2) #2 Phillips, (2) #3 Phillips 1/8", 9/64", 5/32", 3/16", 1/4", 7/32" Allen bits #6, (2) #8, #10 slotted driver bits T8, T9, T10, T15, T20, T25, T30, T40 Torx Res driver bits 1/4" and 3/8" magnetic square drive adaptors 1/4", 3/8", 5/16" magnetic nut setters #2 Phillips 3" long
Features	<ul style="list-style-type: none"> <li>• Heat-treated, shock-resistant tool steel for optimum durability</li> <li>• Assortment of bits for completion of all tasks</li> <li>• Manufactured using the most advanced processes</li> </ul>
<b>HXTXK-11</b>	<b>11-PIECE POWER BIT TORX DRIVE SET</b>
Sizes	T5, T6, T7, T8, T9, T10, T15, T20, T25, T30, T40
Features	<ul style="list-style-type: none"> <li>• Tamper-resistant</li> <li>• Quick-change hex drive for easy removal</li> <li>• Made of high-quality industrial-grade steel</li> </ul>
<b>BHS-3*</b>	<b>3-PIECE BIT HOLDER SET</b>
Sizes	2" and 3" magnetic bit holders, 3" drive guide
Features	<ul style="list-style-type: none"> <li>• Drive guide for easy screw insertion</li> <li>• Magnetic tips for quick change of standard bits</li> <li>• Heat-treated, shock-resistant tool steel for optimum durability</li> </ul>

\*This set does not include case. Comes in blister pack.

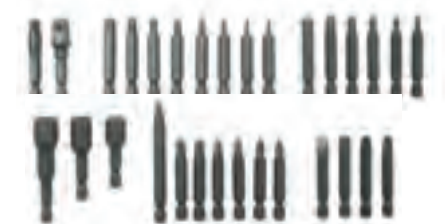



## Drill / Driver Bit Sets

No matter what your drilling needs may be, count on Ingersoll Rand for the bits you require to get the job done. We offer a variety of drill bits and hex driver bits designed specifically for our cordless drills / drivers. (All drill / driver bit sets include case.)

### Black Oxide Bits

These bits are designed for general-purpose, heavy-duty drilling through carbon and alloy steels, aluminum, soft-cast iron, wood, wood composites, and plastics.

Part Number	Description
<b>DBKBO-20E</b>	<b>20-PIECE FRACTIONAL JOBBER LENGTH DRILL BIT SET</b>
Sizes	(2) 1/16", (2) 5/64", (2) 3/32", (2) 7/64", (2) 1/8", 9/64", 5/32", 11/64", 3/16", 7/32", 1/4", 5/16", 3/8", 7/16", 1/2"
Features	<ul style="list-style-type: none"> <li>• High-quality black oxide finish</li> <li>• Fully ground for superior quality</li> <li>• Made with high-speed steel</li> </ul>

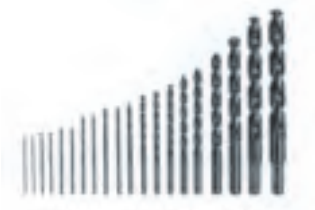

### Titanium-coated Bits

These bits dramatically reduce heat and friction, making them last many times longer than other bits. Titanium bits are designed for repetitive heavy-duty drilling through common stainless steels, carbon and alloy steels, aluminum, soft-cast iron, wood, wood composites, and plastics.

Part Number	Description
<b>DBKTI-20E</b>	<b>20-PIECE TITANIUM FRACTIONAL JOBBER LENGTH DRILL BIT SET</b>
Sizes	(2) 1/16", (2) 5/64", (2) 3/32", (2) 7/64", (2) 1/8", 9/64", 5/32", 11/64", 3/16", 7/32", 1/4", 5/16", 3/8", 7/16", 1/2"
Features	<ul style="list-style-type: none"> <li>• Titanium coating for increased protection</li> <li>• Fully ground for superior quality</li> <li>• Made with high-speed steel</li> </ul>



### Cobalt Bits

These bits withstand high temperature drilling applications for extended periods of time. They're designed for heavy-duty drilling through hardened stainless steels, cast iron, and titanium.

Part Number	Description
<b>DBKCB-20E</b>	<b>20-PIECE COBALT FRACTIONAL JOBBER LENGTH DRILL BIT SET</b>
Sizes	(2) 1/16", (2) 5/64", (2) 3/32", (2) 7/64", (2) 1/8", 9/64", 5/32", 11/64", 3/16", 7/32", 1/4", 5/16", 3/8", 7/16", 1/2"
Features	<ul style="list-style-type: none"> <li>• Integrated cobalt for maximum protection and durability</li> <li>• Fully ground for superior quality</li> </ul>

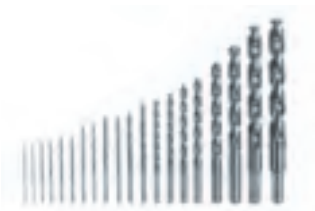

Part Number	Description
<b>SDKTI-3E</b>	<b>3-PIECE STEP DRILL SET</b>
Sizes	1/8" - 1/2" in 1/32" increments; 3/16" - 1/2" in 1/16" increments; 1/4" - 3/4" in 1/16" increments
Features	<ul style="list-style-type: none"> <li>• 1/32" and 1/16" increments for accurately rounded and smooth holes</li> <li>• Titanium-coated to increase working life</li> <li>• Ideal for drilling repetitive holes in steel, copper, brass, plastic, Plexiglas®, and other materials</li> </ul>
<b>DDCMK-28E</b>	<b>28-PIECE DRILL / DRIVE BIT COMBO SET</b>
Pieces length drill bits	1/16", 3/32", 1/8", 5/32", 3/16", 7/32", 1/4", 3/8" fractional jobber
	#6, #8 slotted driver bits T10, T15, T20, T25 Torx drill bits 1/8", 9/64", 5/32", 3/16", 1/4" Allen drill bits 2" magnetic bit holder 3/8" power bit magnetic square drive adaptor 1/4", 5/16", 3/8" power bit magnetic nut setter
Features	<ul style="list-style-type: none"> <li>• Multiple drill bits and driver bits</li> </ul>



## Cordless Boots

Part Number	Description	For Use With
<b>LIGHT HOLDER BOOTS</b>		
W040-BOOT-LED	Premium boot with LED flashlight holder (kit includes LED flashlight)	W040
W150-BOOT-LED	Premium boot with LED flashlight holder (kit includes LED flashlight)	W150

Part Number	Description	For Use With
<b>PROTECTIVE TOOL BOOTS</b>		
W040-BOOT	Cordless Impactool boot with Ingersoll Rand logo printed on red boot	W040
W150-BOOT	Cordless Impactool boot with Ingersoll Rand logo printed on red boot	W150
W360-BOOT	Cordless Impactool boot with Ingersoll Rand logo printed on red boot	W360
D550-BOOT	Cordless drill boot with Ingersoll Rand logo printed on red boot	D550 and D650
D040-BOOT	Cordless mini drill boot and chuck key holder with Ingersoll Rand logo printed on red boot	D040



## Tool Bags and Holsters

Ingersoll Rand tool bags are designed to help you transport your tools as easily and comfortably as possible. Constructed of double-lined ballistic nylon for durability, these bags also feature a padded shoulder strap and handle for increased comfort. Each bag contains ample room for tools as well as spacious inside and outside pockets for storing accessories. Ingersoll Rand tool bags come in three sizes to fit any need.



### Ingersoll Rand Tool Bags and Holsters

Part Number	Description
TB1	16" tool bag
TB2	20" tool bag
TB3	25" tool bag
CDTHS	Small holster for D040 and W040
CDTHL	Large holster for D550, D650, W150, W360



# Air Compressors and System Components



For more than 75 years, Ingersoll Rand has been the world leader in air compressors and air system accessories. We understand the needs and requirements for air systems and the business demands that you face every day. Rising energy costs and reduced margins require increased reliability and efficiency from not only your air compressor, but your entire air system. Simply stated, your air system is much more than an air compressor. It's the complete system — the piping, filters, dryers, drains, hoses, valves, and point-of-use tools.

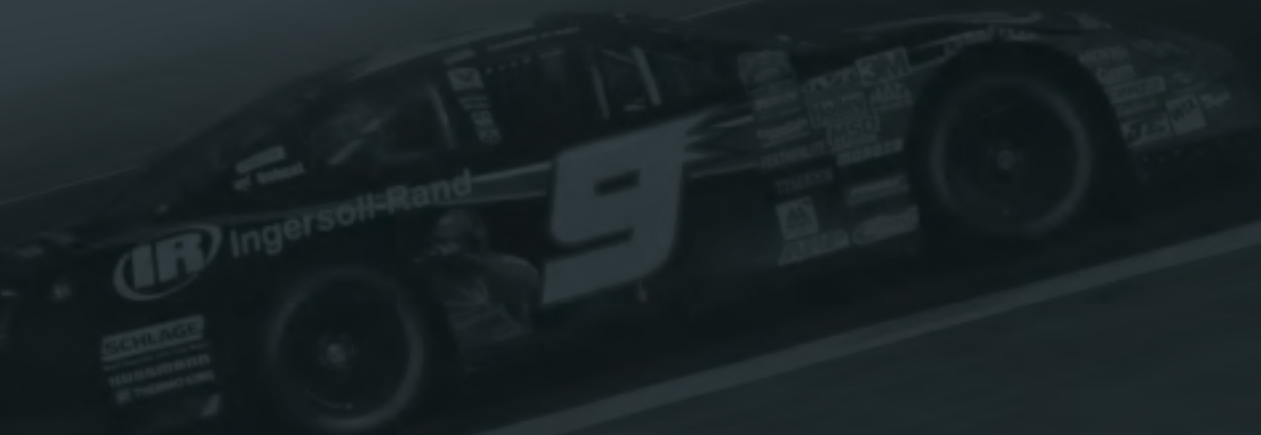

## Selecting an Air Compressor — FAQs

### How will compressed air be used?

The type of work being performed is probably the most important factor in selecting a compressor.

### Where will the compressor be located?

Indoors: heated environment to prevent air lines from freezing while providing sufficient ventilation to cool compressor where elevated temperatures may exist. Outdoors: protection against ambient environment and provisions for cold-weather starting.

### How much pressure (psi) is needed?

Compressor discharge pressure must exceed the psi requirement of all pneumatic tools or equipment being operated.

### How much airflow (cfm) is needed?

Cubic feet per minute (cfm) is the measure of airflow the compressor can create. The measurement cfm is stated in two different forms: piston displacement (pd) or actual cubic feet per minute (acfm). Always consider acfm, as it reflects the amount of useable compressed air.

### What horsepower is required?

Horsepower is directly proportional to the cfm rating of the compressor. The higher the horsepower, the more air (cfm) the compressor can deliver. Do not rely solely on horsepower when specifying or selecting an air compressor.

### What type and size of tank is needed?

The tank provides a reserve of air to meet peak flow and pressure demands. The larger the receiver, the more reserve available. Tanks are available in vertical and horizontal designs; configuration is dependent upon available floor space.

### What are the electrical requirements?

Identify available incoming electrical service before specifying an air compressor. Always have a qualified electrician review electrical requirements.



### Know Your Power Source

All residential and commercial buildings have 115 V / 60 Hz power. Many residential, commercial, and industrial buildings have 230 V / single-phase / 60 Hz power, but this should be confirmed. When electric power is not available, select a gas engine-driven compressor. Do not use a gas engine compressor indoors.

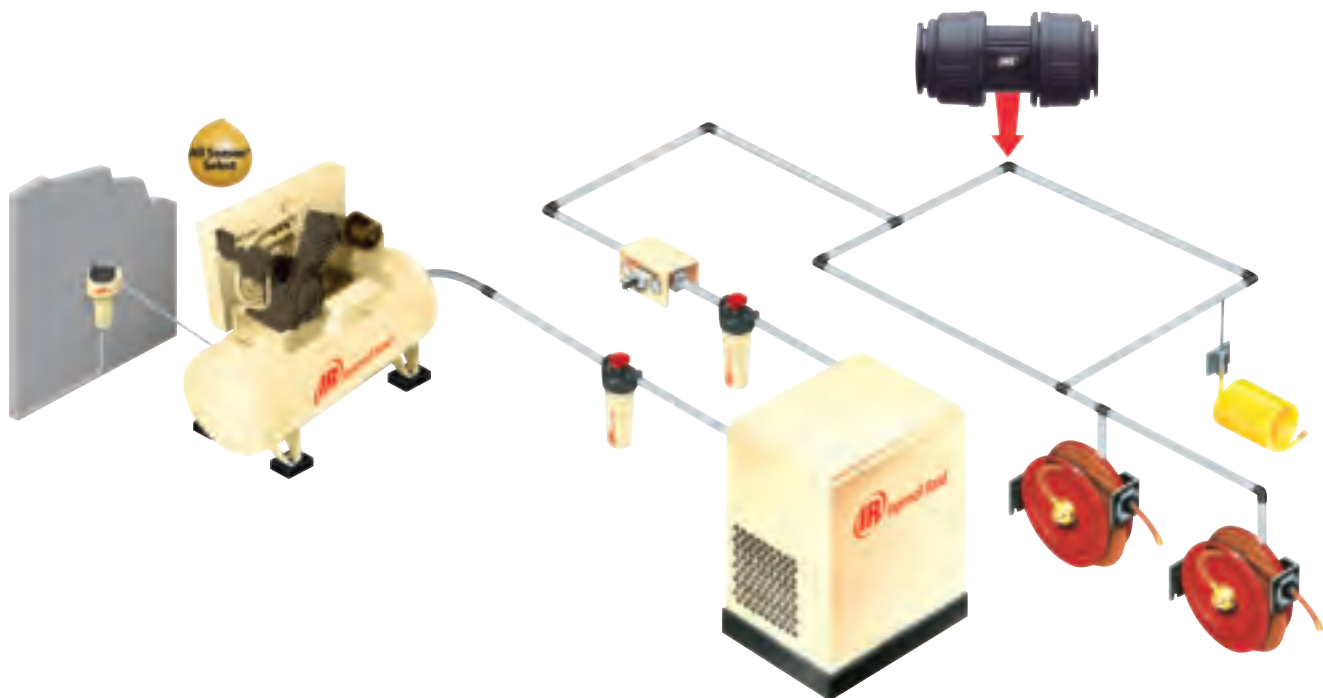

## Single and Two-stage Air Compressors

### Single-stage

Single-stage models compress air to a final pressure in one stroke. They generally are used for pressures between 70 and 90 psi (maximum pressure to 135 psi).

- Oversized belt wheel provides reliable design and cooler operation
- Durable cast-iron cylinders, heads, and frame are designed for continuous operation and extended pump life
- Extended service intervals — Ingersoll Rand synthetic lubricant provides 2,000-hour oil change intervals (four times longer than mineral-based lubricants)
- High-efficiency stainless steel finger valves are simple, efficient, and easy to maintain
- Manual thermal overload protection of the motor — no starter required
- Sight glass makes it easy to check oil level



### Two-stage

A two-stage model compresses air to an intermediate pressure in the first stage, removes heat compression through an intercooler, and compresses air to a final pressure in a second compression stage. Two-stage compressors are more efficient and are generally used for pressures above 100 psi (maximum pressure to 175 psi).

- Two-stage design provides 175 psi operation
- Removable cylinders are easy to repair and provide even 360° cooling, which helps eliminate hot spots
- One-piece connecting rod for fewer wear parts
- Low oil level switch provides constant protection
- Centrifugal unloader ensures loadless starts, providing maximum starter protection
- Finned copper intercooler runs cooler in even the most demanding conditions
- Overhung crankshaft is precision-balanced to run smoothly and quietly
- Splash lubrication is simple and reliable



## Single-stage Air Compressors

Model	Running Power hp	Voltage DC volts	Tank Capacity gal	Airflow @ 90 psi acfm	Max psi	Air NPT Outlet in	Package Dimensions L x W x H in	Net Weight lb
<b>SINGLE-STAGE UNIT — TWIN STACK</b>								
P1IU-A9	2	115-1-60	4.5 twin	4.4	125	3/8"	21" x 15" x 17"	58
<b>SINGLE-STAGE UNITS — GARAGE MATE</b>								
P1.5IU-A9	2	115-1-60	20 vert	5.2	135	3/8"	22" x 23" x 43"	200
SS3F2-GM	2	115-1-60	30 horiz	5.7	135	3/8"	46" x 25" x 35"	185

### Twin-stack

#### Single-stage — Portable

The Ingersoll Rand twin-stack air compressor is designed to provide power, durability, and portability on the jobsite. Built to last, this oil-lube compressor with durable cast-iron cylinders is designed for 100% continuous-duty applications. The twin-stack includes a 1/4" universal coupler, conveniently mounted regulator and pressure gauge, 4.5-gallon twin tanks, All-Season Select® lubricant, and a power cord.

- Lightweight and compact
- Durable cast-iron construction
- Extended pump life — double the life of similar oil-free products



P1IU-A9

### Garage Mate

#### Single-stage — Portable

Designed for professionals and serious do-it-yourselfers, the Garage Mate compact compressor delivers maximum air for impact guns, ratchets, grinders, drills, nail guns, paint sprayers, sanders, and more. This portable single-stage compressor provides the power you need to get the job done faster.

- 100% cast-iron cylinders and frame
- Manual thermal overload motor protection
- Belt-driven for quiet operation — 80 dBA



P1.5IU-A9

## Single-stage Air Compressors

Model	Running Power hp	Voltage DC volts	Engine	Tank Capacity gal	Airflow @ 90 psi acfm	Max psi	Air NPT Outlet in	Package Dimensions L x W x H in	Net Weight lb
<b>WHEELBARROW SINGLE-STAGE — ELECTRIC-DRIVEN</b>									
SS3J2-WB	2	115 / 230-1-60	N/A	8 twin	5.7	135	3/8"	43" x 18" x 25"	175
SS3J3-WB	3	230-1-60	N/A	8 twin	11.3	135	3/8"	43" x 18" x 25"	175
<b>WHEELBARROW SINGLE-STAGE — GASOLINE-DRIVEN</b>									
SS3J5.5GH-WB	5.5	N/A	Honda	8 twin	11.8	135	3/8"	43" x 18" x 25"	175

### Wheelbarrow

#### Single-stage — Portable

Ingersoll Rand electric and gas engine-driven wheelbarrow air compressors are lightweight with a low-profile design to provide maximum maneuverability. Built to last, these cast-iron, oil-lube compressors are designed for 100% continuous-duty applications. Includes pressure switch, regulator, and gauge; two quick disconnects to power multiple tools; and twin 8-gallon capacity tanks. Electric model features a belt drive to provide quiet operation (76 dBA), a 6' power cord, and dual voltage (2-hp model only). Where electric power is not readily available, the gas-driven model is powered by either a 5.5-hp Honda or Briggs & Stratton high-performance engine.

- Designed for maximum maneuverability on the jobsite
- Durable cast iron construction
- 100% continuous-duty for tough applications
- Includes two quick disconnects to power multiple tools



SS3J5.5GH-WB

## Installation Kits

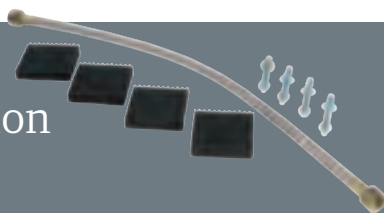

The complete line of Ingersoll Rand Installation Kits can be found on page 79. The complete line of Ingersoll Rand air compressor accessories can be found on pages 76-79.

## Single-stage Air Compressors

Model	Running Power hp	Voltage DC volts	Tank Capacity gal	Airflow @ 90 psi acfm	Max psi	Air NPT Outlet in	Package Dimensions L x W x H in	Net Weight lb
<b>SINGLE-STAGE — ELECTRIC-DRIVEN</b>								
SS3L3	3	230-1-60	60 vert	11.3	135	3/8"	20" x 23" x 66"	300
SS5L5	5	230-1-60	60 vert	18.1	135	1/2"	20" x 30" x 71"	310

### Single-stage

#### Electric-driven

Our single-stage electric air compressors are ideal for almost anyone — from the do-it-yourselfer to the professional air compressor user. Each compressor features durable cast iron construction, 100 percent continuous-duty cycle for the toughest applications, and extended pump life for years of trouble-free service.

- Industrial-quality design
- Durable cast-iron construction
- 135 psi maximum operating pressure



## Two-stage Air Compressors

Model	Running Power hp	Engine	Tank Capacity gal	Airflow @ 175 psi acfm	Max psi	Air NPT Outlet in	Package Dimensions L x W x H in	Net Weight lb
<b>TWO-STAGE TYPE 30 — GAS-DRIVEN</b>								
2475F14G	14	Kohler*	30 horiz	25	175	1/2"	44" x 22" x 46"	424
2475F13GH	13	Honda*	30 horiz	25	175	1/2"	44" x 22" x 41"	430

\*Includes alternator.

### Type 30 Series

#### Gas-driven

Ingersoll Rand Type 30 two-stage compressors meet the needs of fleet or field service applications. Featuring truck-bed mounting, Type 30 units include electronic ignition, idle engine control, a 30-gallon ASME receiver, an OSHA-approved, fully enclosed belt guard, a weather-resistant powdercoat paint finish, and an extended pump life.

- Durable cast-iron construction
- 175 psi maximum operating pressure
- Easy installation
- 100% duty cycle
- Two-year pump warranty with purchase of start-up kit



## Two-stage Air Compressors

Model	Running Power hp	Tank Capacity gal	Airflow @ 175 psi acfm	Max psi	Air NPT Outlet in	Package Dimensions L x W x H in	Net Weight lb	Start-up Kit Part Number
<b>TYPE 30 STANDARD PACKAGE</b>								
2340L5-V	5	60 vert	14.7	175	1/2"	20" x 33" x 69"	400	32305880
2340N5-V	5	80 vert	14.7	175	1/2"	24" x 33" x 67"	475	32305880
2475N5-V	5	80 vert	16.8	175	1/2"	26" x 38" x 70"	500	32305880
2475N7.5-V	7.5	80 vert	24	175	3/4"	26" x 38" x 70"	500	32305880
2545E10-V	10	120 horiz	35	175	3/4"	73" x 28" x 51"	835	32305898
2545EK10-V	10	120 vert	35	175	3/4"	44" x 32" x 82"	985	32305898
7100E15-V	15	120 horiz	50	175	3/4"	72" x 29" x 57"	1,035	32305898

\*Available voltages: 230/1/60 (5 – 7.5 hp only), 200/1/60 ( 2475, 5 hp), 200/3/60, 230/3/60, 460/3/60.  
Please specify voltage required when placing your order.

### Type 30 Value Package

#### 5 to 15 Horsepower

Ingersoll Rand, the world leader in air power, brings industrial-class, two-stage compressors to automotive applications. Featuring a cast-iron pump with splash lubrication for efficient operation and easy serviceability, this new range delivers non-stop performance and reliability for commercial or automotive service applications. Type 30 compressors have been designed to generate maximum air output at 175 psi, with more than 10,000 hours of durability.

- 100% cast iron cylinder head with deep-groove directional cooling fins
- High-efficiency stainless steel valves
- Oversized industrial-grade bearings for extended pump life
- High-efficiency intercooler
- 100% cast iron pump
- High-efficiency inlet air filter with sound attenuation baffles
- Balanced pistons for maximized efficiency and minimized vibration
- Oversized cast-iron balanced belt wheel to allow continuous-duty operation
- Two-year pump warranty with purchase of start-up kit

100% duty cycle motor

Twin-piston, v-style, 100% cast iron pump



2475N7.5



Purchase an Ingersoll Rand start-up kit and increase the warranty on your pump from one year to two years!

## Electric Drain Valves

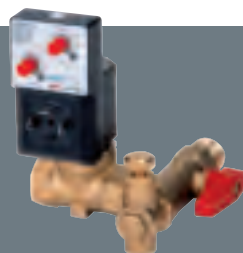

Ingersoll Rand electric drain valves (EDV) are full-feature automatic electronic drain valves that deliver drier air by removing condensate from compressors, receivers, dryers, aftercoolers, filters, and drip legs. Ingersoll Rand air compressor accessories can be found on pages 76-79.

## Two-stage Air Compressors

Model	Running Power hp	Tank Capacity gal.	Airflow @175 psi acfm	Max psi	Air NPT Outlet in	Package Dimensions L x W x H in	Net Weight lb
2545E10-VP	10	120 horiz	35	175	3/4"	72" x 30" x 56"	835
2545K10-VP	10	120 vert	35	175	3/4"	44" x 32" x 82"	830

### Type 30 Value Plus Packages

For applications that demand a heavier-duty cycle. Step up to this enhanced version of our base package. It is ideal for light industry applications. The Value Plus Package comes factory-fitted with options for unmatched reliability in most diversified applications

- 100% Cast-Iron Pump for durability
- 100% Continuous Duty Rating
- Designed to run 24 hours a day
- Two-year pump warranty with purchase of IR start-up kit
- 175 Maximum PSI for greater storage capabilities
- Magnetic starter
- ASME rated Storage Tank
- Auto Start & Stop Control
- Electronic Drain Valve
- Air-cooled After-cooler
- Nation-wide Service Coverage



## Two-stage Air Compressors

Model	Running Power hp	Tank Capacity gal	Airflow @ 175 psi acfm	Max psi	Air NPT Outlet in	Package Dimensions L x W x H in	Net Weight lb	Start-up Kit Part Number
<b>TYPE 30 PREMIUM PACKAGE</b>								
2475N5-P	5	80 vert	16.8	175	3/4"	30" x 37" x 73"	500	32305880
2475N7.5-P	7.5	80 vert	24	175	3/4"	26" x 38" x 70"	500	32305880
2545E10-P	10	120 horiz	35	175	3/4"	72" x 30" x 56"	835	32305898
2545K10-P	10	120 vert	35	175	3/4"	44" x 32" x 82"	850	32305898
7100E15-P	15	120 horiz	50	175	1"	72" x 30" x 56"	1,035	32305898

\*Available voltages: 230/1/60 (5 – 7.5 hp only), 200/3/60, 230/3/60, 460/3/60.  
Please specify voltage required when placing your order.

### Type 30 Premium Packages

In addition to the features on our Value Packages, the Premium Package models include:

- Air-cooled aftercooler to help remove additional moisture
- Low oil protection switch to prevent the pump from running dry
- Electronic drain valve that automatically drains water from compressor tank
- Two-year pump warranty with purchase of start-up kit
- Magnetic motor starter



Purchase an Ingersoll Rand start-up kit and increase the warranty on your pump from one year to two years!

Air Compressors



## Lubricants



All-Season Select lubricant is a synthetic, all-temperature blend designed to increase efficiency, reduce wear, and prevent carbon build-up. Use of All-Season Select lubricant extends pump warranty to two years. Ingersoll Rand air compressor accessories can be found on pages 76-79.



## Rotary Screw Air Compressors

Rotary screw models compress air through two oil-flooded, intermeshed helical screws. This form of compression offers maximum efficiency at much higher air quality levels than reciprocating models with constant pressure capabilities. Rotary screw air compressors can operate 24/7, continuous-duty at extremely quiet noise levels compared to reciprocating compressors, and have up to five times the operating life.

- Low sound — operates at low sound levels of 64 to 69 dBA
- Closely maintained pressure delivers pulse-free air
- 9,000-hour / 2-year coolant — Ultra-Plus coolant offers superior separation for lower coolant make-up, and will not varnish or sludge; improved cooling characteristics reduce operating temperatures, improving the life of the airend



High-efficiency  
Integrated Compression  
Module



Rotary Screw  
Airends

### UP Series 5-15 HP

Model	Running Power hp	Tank Capacity gal	Airflow acfm	Discharge Pressure psi	Air NPT Outlet in	Package Dimensions in	Net Weight lb
UP6-5-125	5	80	18.5 @ 125 psi	125	3/4"	53.6" x 28.9" x 60.7"	925
UP6-5-150	5	80	16 @ 150 psi	150	3/4"	53.6" x 28.9" x 60.7"	925
UP6-7.5-125	7.5	80	28 @ 125 psi	125	3/4"	53.6" x 28.9" x 60.7"	925
UP6-7.5-150	7.5	80	25 @ 150 psi	150	3/4"	53.6" x 28.9" x 60.7"	925
UP6-10-125	10	80	38 @ 125 psi	125	3/4"	53.6" x 28.9" x 60.7"	925
UP6-10-150	10	80	34 @ 150 psi	150	3/4"	53.6" x 28.9" x 60.7"	925
UP6-15c-125	15	80	55 @ 125 psi	125	3/4"	53.6" x 28.9" x 60.7"	925
UP6-15c-150	15	80	50 @ 150 psi	150	3/4"	53.6" x 28.9" x 60.7"	925

Our 5-15HP UP Series rotary screw air compressors provide best-in-class performance in rotary screw technology. Each compressor package comes standard with 230 / 460-3-60 ODP electric motor, air-cooled aftercooler to reduce discharge air temperatures, full voltage motor starter that is mounted and wired (wired for 230-3-60 voltage standard), dual control (auto start and stop, constant speed control), low sound / full sheet metal enclosure, package pre-filter, 9,000-hour rated Ultra-Plus coolant, spin-on oil filter and separator element, A.S.M.E coded horizontal receiver tank with electric drain valve, and NEMA-1 electrical protection. These models operate at 64 to 69 dBA.

Recommended accessories:

- Installation kit (page 79)
- Maintenance kit (page 79)



## Rotary Screw Air Compressors

### UP Series 5-15 HP Total Air System

Model	Running Power hp	Tank Capacity gal	Airflow acfm	Operating Pressure psi	Discharge Pressure psi	Air NPT Outlet in	Package Dimensions in	Net Weight lb
UP6-5TAS-125	5	80	18.5 @ 125 psi	125	115	3/4"	53.6" x 28.9" x 60.7"	1,000
UP6-5TAS-150	5	80	16 @ 150 psi	150	140	3/4"	53.6" x 28.9" x 60.7"	1,000
UP6-7.5TAS-125	7.5	80	28 @ 125 psi	125	115	3/4"	53.6" x 28.9" x 60.7"	1,000
UP6-7.5TAS-150	7.5	80	25 @ 150 psi	150	140	3/4"	53.6" x 28.9" x 60.7"	1,000
UP6-10TAS-125	10	80	38 @ 125 psi	125	115	3/4"	53.6" x 28.9" x 60.7"	1,000
UP6-10TAS-150	10	80	34 @ 150 psi	150	140	3/4"	53.6" x 28.9" x 60.7"	1,000
UP6-15cTAS-125	15	80	55 @ 125 psi	125	115	3/4"	53.6" x 28.9" x 60.7"	1,000
UP6-15cTAS-150	15	80	50 @ 150 psi	150	140	3/4"	53.6" x 28.9" x 60.7"	1,000

Are you looking to save space and installation cost by having a complete clean, dry air system in a single package? The UP Series 5-15 HP Total Air System (TAS) is an innovative solution to your compressed air needs. The TAS has the same features and benefits of the standard UP Series 5-15HP unit, but also comes standard with an Energy Star cycling refrigerated air dryer with stainless steel heat exchanger, integrated compressor and dryer controls for optimum operation, panel-mounted dew point indicator, dual filters (general purpose and high-efficiency) mounted and piped, single-point condensate drain system with electric drain (115-volt), and high-efficiency moisture separator. These models operate at 64 to 69 dBA.

- Two coalescing filters: general purpose and high-efficiency
- Cycling refrigerated air dryer
- Pre-piped, single-point condensate drain system
- Eliminates up to 80 percent of traditional installation cost of individual air treatment equipment
- Intelligent design separates temperature-sensitive components and air treatment center on "cool side" from heat generating airoend on the "hot side"



Recommended accessories:

- Installation kit (page 99)
- Maintenance kit (page 99)

## Maintenance Kits



The competitively priced Maintenance Kit includes all parts required for every 3,000-hour or annual maintenance of your UP-Series rotary compressor. Ingersoll Rand air compressor accessories can be found on pages 76-79.

## Refrigerated Dryers

Ingersoll Rand refrigerated air dryers protect your tools, machinery, and equipment from harmful moisture while saving energy and reducing system downtime. The unique design improves dryer efficiency and minimizes maintenance by using fewer moving parts. The easy-to-read diagnostic controls provide a constant indication of dryer performance. Units are compact, lightweight, and can be easily installed. Ingersoll Rand refrigerated air dryers are ideal for general industrial applications, and they use environmentally friendly refrigerants.

Protect your downstream equipment by preventing 100% saturated compressed air from rusting tools, and washing away lubricants with a refrigerated dryer. Ingersoll Rand's ISO class 6 refrigerated dryer can handle air flows from 7 to 212 SCFM. The dryer's corrosion resistant heat exchanger is reliable and operationally efficient with low pressure drop and optimized dewpoint performance. An enhanced refrigeration control-system and high-efficiency stainless steel moisture-separation ensure a steady long-term supply of dry air. A variable speed fan further ensures continuous heat removal. Simple controls provide user-friendly operation and a fully adjustable programmable electronic drain valve helps minimize air loss.

Enhance your system's protection by adding superior Ingersoll Rand air filters found on page 91. Continuous long-life operation from your refrigerated dryer is enhanced by installing a dryer pre-filter. Prior to the dryer use the recommended GP particulate filters. HE coalescing oil removal filters virtually eliminate cost due to ruined product finishes, scrapped materials or replacement of pneumatic tools and manufacturing equipment destroyed by contaminated air.



### Sizing Table

Site conditions will affect the performance of your refrigerated dryer. Determine your site conditions and multiply the dryer capacity by each factor to determine the air flow that dryer is capable of.

Dryer Inlet Air Temp °F	Correction Factor	Ambient Air Temp °F	Correction Factor	Inlet Pressure psig	Correction Factor
80	1.3	80	1.1	73	0.85
<b>100</b>	<b>1</b>	<b>100</b>	<b>1</b>	<b>102</b>	<b>1</b>
120	0.6	110	0.83	145	1.15
140	0.25	122	0.65	174	1.2
NA	NA	NA	NA	203	1.24

Model	Capacity scfm	Nominal Power Consumption kW	Voltage	Connection size	in			Max Inlet Temp °F	Weight lb
D12IN	7	0.16	115/1/60	1/2"	12	16	16	140	40
D18IN	11	0.16	115/1/60	1/2"	12	16	16	140	40
D25IN	15	0.16	115/1/60	1/2"	12	16	16	140	40
D42IN	25	0.21	115/1/60	1/2"	16	18	18	140	60
D54IN	32	0.37	115/1/60	1/2"	16	18	18	140	62
D72IN	42	0.37	115/1/60	1/2"	16	18	18	140	62
D108IN	64	0.48	115/1/60	1/2"	16.5	21.5	22.5	140	77
D144IN	85	0.57	115/1/60	1/2"	16.5	21.5	22.5	140	82
D180IN	106	0.71	115/1/60	1"	16.5	21.5	22.5	140	104
D300IN	176	1.25	230/1/60	1-1/2"	20	25.5	38.5	140	192
D360IN	212	1.25	230/1/60	1-1/2"	20	25.5	38.5	140	192

## Air Compressor Accessories

### Electric Drain Valves (EDV)

Ingersoll Rand electric drain valves (EDV) are full-feature automatic electronic drain valves that deliver drier air by removing condensate from compressors, receivers, dryers, aftercoolers, filters, and drip legs.

#### Features / Benefits

- Extend life of pneumatic equipment and tools
- Eliminate manual draining
- Prevent rusting and clogging
- 2-year warranty
- Maximum 250 psi



Voltage 110 / 120 V	Voltage 230 / 240 V	Inlet Pipe Connection	Outlet Pipe Connection	Orifice
<b>ELECTRONIC DRAIN VALVES (EDV)</b>				
37995925	37995933	0.5 NPT	0.25 NPT	3/32"
54410931	37995909	0.5 NPT	0.25 NPT	7/16"
37995891	37995917	0.5 NPT	0.5 NPT	7/16"
38000865	38000873	0.5 BSP	0.25 BSP	7/16"
38000808	38000881	0.5 BSP	0.5 BSP	7/16"
54579248*	97339402	JIC-14	0.25 NPT	3/32"

\*JIC connection for field retrofits on T30 compressors.

Part Number	Description
<b>ELECTRONIC DRAIN VALVES (EDV)</b>	
54381090	1/2" x 1/4" male NPT valve connection
37996337	1/2" x 1/4" male NPT valve connection
38000154	Stainless steel filter screen
54381090	JIC — 1/4" x 1/4" NPT

## In-line Air Filters

Ingersoll Rand coalescing filters save energy and protect your tools, machinery, and equipment from harmful contaminants by effectively removing solid particulates, liquid water, oil, and aerosols from compressed air.

Unique in design, these in-line filters allow simple and fast maintenance with a patented zero-clearance element removal. Lighted indication ensures continued filtration performance. When it is time to replace the filter element, the lighted Element Change Indicator will illuminate with a rapid flash allowing your process to be continuously protected while minimizing the pressure drop in the compressed air system – saving you money.

Our general purpose filters remove particulates down to 1.0 micron, which meets general industry requirements for coarse filtration. Our high-efficiency filters remove contaminants down to 0.01 micron, which meets difficult compressed air filtration requirements.



"G" General Purpose Filter Model*	"H" High-Efficiency Filter Model**	Flow Rating	Max Pressure psi	Inlet/Outlet NPT	Micron Rating		Dimensions	
					"G" Models	"H" Models	H	W
F35IG	F35IH	21	250	1/2"	1	0.01	10.0"	3.0"
F71IG	F71IH	42	250	3/4"	1	0.01	12.25"	3.84"
F108IG	F108IH	64	250	3/4"	1	0.01	12.25"	3.84"
F144IG	F144IH	85	250	1"	1	0.01	13.4"	5.08"
F178IG	F178IH	105	250	1"	1	0.01	13.4"	5.08"
F212IG	F212IH	125	250	1"	1	0.01	13.4"	5.08"
F395IG	F395IH	233	250	1-1/2"	1	0.01	16.9"	5.08"
F424IG	F424IH	250	250	1-1/2"	1	0.01	16.9"	5.08"

\*G = General Purpose, 1 micron rating

\*\* H = High Efficiency, 0.01 micron rating

Replacement Element	Part Number
<b>GENERAL PURPOSE REPLACEMENT FILTER ELEMENTS</b>	
F35IG	85565505
F71IG	85565547
F108IG	85565588
F144IG	85565620
F178IG	85565661
F212IG	85565703
F395IG	85565745
F424IG	85565786
<b>HIGH-EFFICIENCY REPLACEMENT FILTER ELEMENTS</b>	
F35IH	85565513
F71IH	85565554
F108IH	85565596
F144IH	85565638
F178IH	85565679
F212IH	85565711
F395IH	85565752
F424IH	85565794

## Air Compressor Accessories

### Start-up Kits for Air Compressors

Start-up kits include all the parts needed to maintain your compressor for one year, plus the added protection of extended warranty coverage. Kits include:

- All-Season Select® lubricant — a synthetic, all-temperature blend designed to increase efficiency, reduce wear, and prevent carbon build-up
- Replacement filter elements
- Engine oil and filters are also included in kits for gas-driven compressors
- 2-year extended warranty (pump only) based on use of All-Season Select lubricant included in kit



Model	Part Number
<b>ELECTRIC START-UP KITS</b>	
SS3	97338099
SS5	20100251
2000	20102877
2340, 2475	32305880
2545, 7100, 2545N7.5-PS, 7100E10-PS	32305898

Model	Make	Part Number
<b>GAS START-UP KITS</b>		
SS3J5.5GB-WB	Briggs & Stratton	97338610
SS3J5.5GH-WB	Honda	97339501
SS3J5.5GH-AS	Honda	97339501
2475F11GH	Honda	32312936
2475F11.5GKA	Kawasaki	32498511
2475F12.5G	Kohler	32305872
2475F13GH	Honda	32312936
2475F14G	Kohler	46821567



Start-up Kit for Gas-driven Air Compressors

### Lubricants

#### All-Season Select Lubricant

All-Season Select lubricant is a synthetic, all-temperature blend designed to increase efficiency, reduce wear, and prevent carbon build-up. It performs four times longer than petroleum-based lubricants. Recommended 2,000 hours of service between lubricant change-out under normal operating conditions.



Coolant / Lubricant	Base Stock	Viscosity Index	Hours	ISO Viscosity Grade	SAE Grade
<b>LUBRICANT</b>					
All-Season Select	Diester	128	2,000	68 / 150	20W40

All-Season Select	Quantity	Part Number
<b>LUBRICANT</b>		
Box of quarts	(12) 1 qt	34836739
Box of 1/2 liters	(6) 1/2 liter	97338149

### Rotary Start Up Kits and Accessories

Part Number	Description
<b>ROTARY START-UP KITS</b>	
38339297	UP6 5-15c
38028577	UP6 20-40
<b>ACCESSORIES</b>	
38342028	Panel Filter: UP6 5-15c (4-Pack)
38338463	Electrical Installation Kit: 1-phase UP6 5-15c
22469183	Maintenance Kit: UP6 5-15c
38335410	Installation Kit: UP6 5-15c

## Maintenance Kits — TS and SS Series Compressors

Ingersoll Rand Type 30 maintenance kits offer all the parts necessary to perform annual factory-recommended maintenance on your Type 30 compressor. Conveniently packaged, the kits can save you 20 to 30 percent more than purchasing parts individually.

### Features

- One fill of All-Season Select lubricant
- One replacement air filter element
- All replacement gaskets and O-rings required to clean and inspect valves
- Easy-off maintenance reminder sticker to track when next maintenance is due



## Single-Stage Maintenance Kits

Model	Valve / Gasket Kit	Ring / Gasket Kit	Bearing Kit	Air Filter	Overhaul Kit	Gasket Kit
<b>MAINTENANCE KITS</b>						
SS3 electric units	97338107	97338115	N/A	70243712	N/A	N/A
SS5 electric units	20100277	20100285	N/A	32170979	N/A	N/A
2000 electric units	20103081	20103099	20103107	32170979	22222053	N/A

## Two-Stage Maintenance Kits

Model	Maintenance Kit
<b>COMPRESSOR MAINTENANCE KITS</b>	
2340	38485314
2475	38485330
2545	38485298
7100	38485322



## Installation Kits

Kit Number	Description	Part Number	Quantity
<b>1/2" STANDARD INSTALLATION KITS</b>			
38335402*	Vibration pads	32321002	4
	1/2" x 3' braided hose	38335295	1
	1/2" JIC to NPT male adaptor	38335337	2
	1/2" x 4" foundation bolts	38335329	4
	Instruction sheet	22256549	1
<b>3/4" STANDARD INSTALLATION KITS</b>			
38335410**	Vibration pads	32321002	4
	3/4" x 3' braided hose	38335303	1
	3/4" JIC to NPT male adaptor	38335345	2
	1/2" x 4" foundation bolts	38335329	4
	Instruction sheet	22256549	1
<b>1" STANDARD INSTALLATION KITS</b>			
38335394	1" x 3' braided hose	38335311	1
	1" JIC to NPT male adaptor	38335352	2
	1/2" x 4" foundation bolts	38335329	4
	Instruction sheet	22256549	1

\*For compressor models SS3, SS5, 2340, and 2475 electric units.

\*\*For compressor models 2475, 2545, and 7100 electric units.

# Lubrication Equipment



Ingersoll Rand lubrication equipment reflects the same high standards of performance as Ingersoll Rand tools and air compressors, with a full range of products that will keep all types of fluids moving efficiently. They are backed by more than 70 years of experience in pump and air system technology, and include models specifically designed for popular applications.





## ARO LM and LP Series Piston Pumps

### Built Tough to Fit the Way You Work

Ingersoll Rand LM Series piston pumps deliver unmatched industrial-strength performance for pumping fluids with sizes to fit small (16 gal / 35 lb) or large (275 gal / 400 lb) containers. Working flow rates range from 2 to 6 gallons per minute. Pumps are offered from 3:1 to 50:1 ratios, in order to meet the requirements of any application. Our LM Series is ideal for pumping grease, motor oil, gear oil, or transmission fluid. The simple, durable design allows for piston pump service by any owner or qualified technician. Also look for our convenient grease and oil pump packages.

### Features and Benefits

- Pump's patented design improves flow, reduces pulsation, and extends service life
- Offers simple self-service maintenance due to advanced design with 50% fewer parts
- Reduces service time, due to inline service design with no special tools required
- Features stall-free, ice-free air motor with tough, durable housing

### Inline Service for 3:1 Piston Pumps



*One standard wrench to loosen four nuts...*



*...allows you to replace all dynamic service kit items — no additional wrenches required for 3:1...*



*...and put pump back in service in a matter of minutes.*

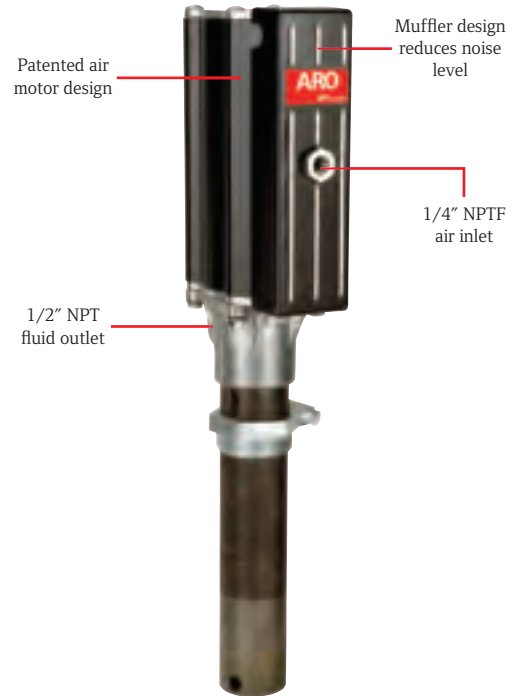

## LM Series Piston Pumps

Model	Working Flow gpm (L/min)	Free Flow gpm (L/min)	Fluid Inlet / Outlet NPTF in (mm)	Container gal	Air Inlet in (mm)
<b>3:1 PISTON PUMPS</b>					
LM2203A-11-C	6 (23)	9 (34)	3/4" / 1/2" (19 / 13)	Stub	1/4" (6)
LM2203A-31-C	6 (23)	9 (34)	3/4" / 1/2" (19 / 13)	16	1/4" (6)
LM2203A-41-C	6 (23)	9 (34)	3/4" / 1/2" (19 / 13)	55	1/4" (6)
LM2203A-51-C	6 (23)	9 (34)	3/4" / 1/2" (19 / 13)	275	1/4" (6)
<b>5:1 PISTON PUMPS</b>					
LM2305A-11-B	6 (23)	9 (34)	1-1/2" / 1/2" (38 / 13)	Stub	1/4" (6)
LM2305A-31-B	6 (23)	9 (34)	1-1/2" / 1/2" (38 / 13)	16	1/4" (6)
LM2305A-41-B	6 (23)	9 (34)	1-1/2" / 1/2" (38 / 13)	55	1/4" (6)
LM2305A-51-B	6 (23)	9 (34)	1-1/2" / 1/2" (38 / 13)	275	1/4" (6)
<b>50:1 PISTON PUMPS</b>	<b>ppm (kg/min)</b>	<b>ppm (kg/min)</b>	<b>Outlet NPTF in</b>	<b>Weight lb</b>	
LM2250E-21-B	2 (1)	9 (4)	3/8"	35	1/4" (6)
LM2250E-31-B	2 (1)	9 (4)	3/8"	120	1/4" (6)
LM2250E-41-B	2 (1)	9 (4)	3/8"	400	1/4" (6)
LM2250E-61-B	2 (1)	9 (4)	3/8"	60	1/4" (6)
LM2350E-21-B	4 (2)	7.5 (3)	3/8"	35	1/4" (6)
LM2350E-31-B	4 (2)	7.5 (3)	3/8"	120	1/4" (6)
LM2350E-41-B	4 (2)	7.5 (3)	3/8"	400	1/4" (6)
LM2350E-61-B	4 (2)	7.5 (3)	3/8"	60	1/4" (6)

## LP Series Piston Pumps

Model	Description	Pump	Meter	Control Handle	Dolly	Drum Cover	Hose	Valve			
<b>PORTABLE OIL PUMP PACKAGES</b>											
LP2100-1-B	3:1 ratio, 16 gal	LM2203A-31-C	635190-1	635190-1	640058-2	94421	623501-6	67085			
LP3100-1-B	5:1 ratio, 16 gal	LM2305A-31-C	635190-1	635190-1	640058-2	94421	623501-6	N/A			
Model	Description	Pump Meter	Handle	Control Dolly	Cover	Drum Hose	Plate	Follower Handle	Adaptor	Z-Swivel	
<b>GREASE PUMP PACKAGES</b>											
LP2001-1-B	2" diameter air motor, 35 lb	LM2250E-21-B	N/A	N/A	N/A	94420	N/A	640095-2-B	94434	N/A	N/A
LP2002-1-B	2" diameter air motor, 35 lb	LM2250E-21-B	N/A	636111	N/A	94420	624201-10	640095-2-B	94434	76493	636077
LP2003-1-B	2" diameter air motor, 120 lb	LM2250E-31-B	N/A	N/A	N/A	94421	N/A	640165	N/A	N/A	N/A
LP2004-1-B	2" diameter air motor, 120 lb	LM2250E-31-B	N/A	636111	N/A	94421	624201-10	640165	N/A	76493	636077
LP2006-1-B	2" diameter air motor, 120 lb	LM2250E-31-B	N/A	636111	640058-2	94421	624201-10	640165	N/A	76493	636077
LP3001-1	3" diameter air motor, 35 lb	LM2350E-21-B	N/A	636103	N/A	94420	624201-10	640095-2-B	94434	76493	636077
LP3002-1	3" diameter air motor, 120 lb	LM2350E-31-B	622201-3	N/A	N/A	94421	624401-4	640165	N/A	N/A	N/A
LP3003-1	3" diameter air motor, 120 lb	LM2350E-31-B	N/A	636103	N/A	94421	624401-4	640165	N/A	76493	636077
LP3004-1	3" diameter air motor, 120 lb	LM2350E-31-B	N/A	636111	N/A	94421	624401-4	640165	N/A	76493	636077
LP3005-1	3" diameter air motor, 400 lb	LM2350E-41-B	622201-3	N/A	N/A	94421	624401-4	640165	N/A	N/A	N/A
LP3007-1	3" diameter air motor, 60 lb	LM2350E-61-B	N/A	636111	N/A	71740-1	624401-4	N/A	N/A	N/A	N/A



LP3001-1



LP3003-1



LP3100-1-B

## Piston Pumps

Model	Working Flow gpm (L)	Free Flow gpm (L)	Air Inlet NPT (F) in	Fluid Outlet NPT (F) in	Container gal (L)	Accessories
<b>SERIES 200 PISTON PUMPS — 1:1 RATIO 2" DIAMETER AIR MOTOR</b>						
612041-1	9 (34)	18 (68)	1/4"	3/4"	55 (208.2)	Bung adapter
612041-3*	9 (34)	18 (68)	1/4"	3/4"	55 (208.2)	Bung adapter
612042-1	9 (34)	18 (68)	1/4"	3/4"	275 (1041)	Bung adapter
<b>SERIES 425 PISTON PUMPS — 9:1 RATIO 4.25" DIAMETER AIR MOTOR</b>						
662420-B*	3.9 (14.8)	21 (79.4)	1/4"	3/4"	Stub	N/A
662409*	3.9 (14.8)	21 (79.4)	1/4"	3/4"	16 (60.57)	N/A
662410-B	3.9 (14.8)	21 (79.4)	1/4"	3/4"	55 (208.2)	N/A

\*Not pictured.

### PISTON PUMPS

#### Motor Oil, Gear Oil, and Transmission Fluid

#### 612041-1

This 1:1 ratio pump is ideal for pumping motor oil, gear oil, and transmission fluid. This model fits a standard 55-gallon drum (including bung adapter).



#### 612042-1

Our 1:1 ratio piston pumps are ideal for moving oils and fluids at high volumes. This model is designed for 275-gallon onboard tanks.



#### 662410-B

425 Series pumps are designed with a 9:1 pump ratio, 1/4" air motor, and are ideal for pumping heavy oils over long distances.



## ARO Diaphragm Pumps

Our diaphragm pumps are ideal for pumping oil or other light fluids such as anti-freeze, water, windshield fluid, fuel, solvents, transmission fluid, and waste oil. ARO diaphragm pumps range in size from 3/8" to 2" to meet the requirements of any application.

### Features and Benefits

- Ideal for abrasion and solids handling
- From top to bottom, ARO's flap valve pump is your best high solids-handling choice
- Bolted construction for reliability and ease of assembly
  - Bolted is safer
  - Bolted is reliable
  - Bolted is easier to assemble
  - Bolted is less expensive
- Positive priming provides instant start-ups
- ARO's patented "unbalanced" air valve
  - Eliminates shifting / freezing problems
  - Uses significantly less power than competition
  - Does not require lubrication
  - Forgiving in dirty air
- Uninstallable air motor design: SimulShift™
- Broad material selection
- Commitment — Ingersoll Rand diaphragm pumps come with a 5-year warranty.

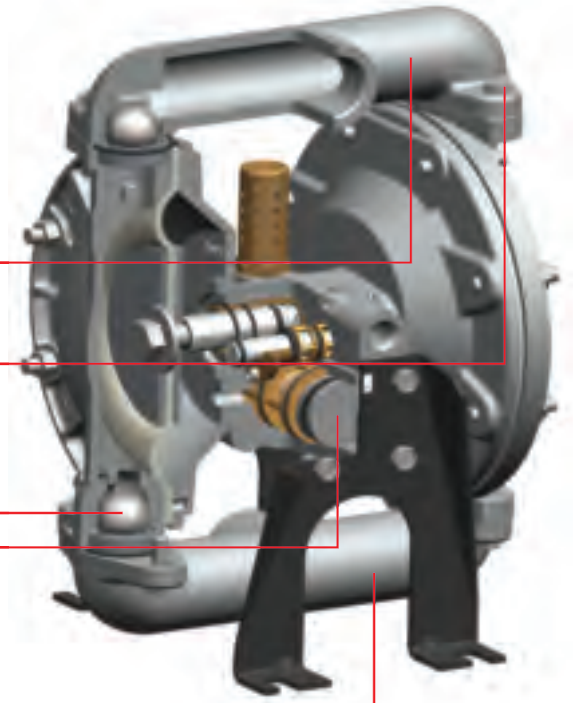

## Diaphragm Pumps

Model	Body Materials (Wetted)	Diaphragm / Ball Material	Air Inlet NPT (F) in	Fluid Inlet / Outlet Material in	Max Flow gpm	Compatible Fluids	Replaces Model
<b>3/8" PORTS</b>							
PD03P-ARS-PTT	Polypropylene	Teflon and anti-freeze	1/4"	3/8"	10.6	Windshield fluid, motor / gear oil, transmission fluid	New
PD03P-ARS-PCC	Polypropylene	Hytrel	1/4"	3/8"	10.6	windshield fluid, motor / gear oil, transmission fluid, anti-freeze	New
PD03P-AES-DTT	Acetal (groundable)	Teflon	1/4"	3/8"	10.6	Solvents	New
PD03P-AES-DCC	Acetal (groundable)	Hytrel	1/4"	3/8"	10.6	Windshield fluid, motor / gear oil, transmission fluid, anti-freeze	New
<b>1/2" PORTS</b>							
PD05P-ARS-PTT-B	Polypropylene	Teflon	1/4"	1/2"	14.4	Windshield fluid, motor / gear oil, transmission fluid, anti-freeze	66605J-344
PD05P-ARS-PCC-B	Polypropylene	Hytrel	1/4"	1/2"	14.4	Windshield fluid, motor / gear oil, transmission fluid, anti-freeze	66605J-322
PD05P-ARS-PAA-B	Polypropylene	Santoprene	1/4"	1/2"	14.4	Windshield fluid / anti-freeze	66605J-388
PD05P-AES-DTT-B	Acetal	Teflon	1/4"	1/2"	14.4		666056-6A4
PD05P-AES-DCC-B	Acetal	Hytrel	1/4"	1/2"	14.4	Windshield fluid, motor / gear oil, transmission fluid, anti-freeze	66605H-622
66605J-344*	Polypropylene	Teflon	1/4"	1/2"	13	Windshield fluid, motor / gear oil, transmission fluid, anti-freeze	

\*These pumps have been superseded and will be discontinued in the near future. See recommended replacements above.

## Diaphragm Pumps

Model	Body Materials (Wetted)	Diaphragm / Ball Material	Air Inlet NPT (F) in	Fluid Inlet / Outlet Material in	Max Flow gpm	Compatible Fluids
<b>1/2" PORTS</b>						
66605J-322	Polypropylene	Nitrile	1/4"	1/2"	13	Windshield fluid, motor / gear oil, transmission fluid, anti-freeze
66605J-388	Polypropylene	Polyurethane	1/4"	1/2"	13	Windshield fluid, motor / gear oil, transmission fluid, anti-freeze
<b>1" PORTS</b>						
666100-344-C	Aluminum	Teflon	1/4"	1"	35	Windshield fluid, motor / gear oil, transmission fluid, anti-freeze, solvents
666100-362-C	Aluminum	Nitrile / acetal	1/4"	1"	35	Windshield fluid, motor / gear oil, transmission fluid, anti-freeze
666100-3C9-C	Aluminum	Hytrel	1/4"	1"	35	Windshield fluid, motor / gear oil, transmission fluid, anti-freeze
666100-322-C	Aluminum	Buna	1/4"	1"	35	Windshield fluid, motor / gear oil, transmission fluid, anti-freeze
650717-C	Aluminum	Viton / acetal	1/4"	1"	29	Fuel (UL 79 approved)
<b>1-1/2" PORTS</b>						
666150-362-C	Aluminum	Nitrile / acetal	1/2"	1-1/2"	90	Windshield fluid, motor / gear oil, transmission fluid, anti-freeze
650718-C	Aluminum	Viton / acetal	1/2"	1-1/2"	75	Fuel (UL 79 approved)
<b>2" PORTS</b>						
666250-9C9-C	Aluminum	Hytrel	3/4"	2"	172	Windshield fluid, motor / gear oil, transmission fluid, anti-freeze
650719-C	Aluminum	Viton / acetal	3/4"	2"	105	Fuel (UL 79 approved)

### 650715-C

This 1:1 ratio pump has dual inlets to allow simultaneous pumping and blending of anti-freeze and water.



## Specialty Application Pumps Specifications

Model	Application	Manifold Material	Diaphragm and O-Ring Material	Air Inlet NPT (F) in (mm)	Fluid Outlet NPT / F in (mm)	Max gpm (L/min)	Package Includes
<b>1/2" PORTS</b>							
612999-5	Waste oil evacuation	Polypropylene	Nitrile	1/4" (6)	1/2" (13)	11 (42)	Wall mount, inlet and outlet fluid hoses
612999-6	Waste oil evacuation	Polypropylene	Nitrile	1/4" (6)	1/2" (13)	11 (42)	Hanging bracket and outlet hose
<b>1" PORTS</b>							
650715-C	50/50 mix of anti-freeze and water	Aluminum	Nitrile	1/4" (6)	1" (25)	35 (133)	Pump only
612999-3	50/50 mix of anti-freeze and water	Aluminum	Nitrile	1/4" (6)	1" (25)	35 (133)	Wall mount, siphon tubes, material hoses
612999-4	Waste oil evacuation	Aluminum	Nitrile	1/4" (6)	1" (25)	35 (133)	Wall mount, inlet and outlet fluid hoses
613201-2-C	Calcium chloride tire filling	Aluminum	Neoprene	1/4" (6)	1" (25)	35 (133)	Inlet and outlet hoses, strainer, 8' suction hose, control handle, check valve

## Ingersoll Rand Heavy-duty Hose Reels

Model	Performance Rating	Max Pressure	Hose Length ft	Hose ID in	Inlet / Outlet NPT	Dimensions (in)			Spool Material	Use
						Length in	Width in	Height in		
<b>LOW-PRESSURE HOSE REELS</b>										
6332	Heavy-duty	300	35'	1/2"	3/8" / 1/2"	17.75"	7"	20.37"	Composite	Air, water, compatible solvents
6358	Heavy-duty	300	50'	3/8"	3/8" / 3/8"	17.75"	7"	20.37"	Composite	Air, water, compatible solvents

### 6358

#### Hose Reel

##### Low-pressure

This composite hose reel provides excellent durability at a great value. All composite reels are made of a tough glass-filled material combined with a strong steel base.



## Hose Reel Accessories



Accessory	Model	Compatible With	Features
OH mounting bracket	7001	Ultra-duty	Overhead mounting bracket for I or H beam, 5" x 6" flange
OH mounting bracket	7009	Supreme-duty	Overhead mounting bracket for I or H beam, 8" x 9" flange
Wall-mount swing bracket	7002	Ultra-duty	Swing bracket (180°) for vertical mounting
Floor-mount swivel bracket	7003	Ultra-duty and supreme-duty	Swivel bracket (345°) for horizontal mounting
Ceiling-mount bracket, requires 7005	7004	Ultra-duty	Easy installation bracket; reel slides in and out for easy overhead mounting; must be ordered with 7005 for I or H beam installation
I or H beam adapter, requires 7004	7005	Ultra-duty	Easy installation bracket; I or H beam adapter; must be ordered with 7004.
Wall-mount swing bracket	7006	Supreme-duty	Vertical mounting bracket (180°); powdercoated crinkle black
Reelcraft adapter plate	7007		Custom adapter bracket for Reelcraft 4000, 5000, 5806, and 7000 Series 3" x 5" and 4" x 5" base patterns
Graco adapter plate	7008		Custom adapter bracket for Graco 500 Series 3" x 5" and 4" x 5" base patterns

## Control Handles

### Non-metered Fluid Control Handles

Model	Description	Max Working Pressure psi (bar)	Fluid Inlet NPT (F) in	Fluid Outlet
<b>MOTOR OIL, GEAR OIL, TRANSMISSION FLUID</b>				
<b>HIGH-VOLUME</b>				
635193	Has flexible rubber hose with a non-drip nozzle; use with 1:1 and 3:1 pumps; non-drip tip	600 (41)	3/4"	71893
635395-2	Has flexible rubber hose with non-drip nozzle; use with 5:1 and 9:1 pumps; non-drip tip	900 (63)	3/4"	71893
<b>STANDARD-VOLUME</b>				
635392	Has flexible rubber hose, built-in swivel and filter, and non-drip nozzle; non-drip tip	1,000 (69)	1/2"	60164
635399	Has flexible rubber hose, built-in swivel, and right-angle non-drip nozzle; non-drip tip	1,000 (69)	1/2"	70790
<b>WATER, ANTI-FREEZE</b>				
635129	Radiator bib	300 (21)	1/4"	Non-drip tip



635193



635399



635392

### Digital, Metered Fluid Control Handles

Our new metered control handle features a patented oval gear wheel design for precise reliable measurement. Its digital LCD readout operates on two standard alkaline batteries.

- Lightweight
- Precise
- Fast reset
- Totalizes

Model	Max Flow Rate gpm (L)	Meter / Totalizing Increments	Max. Working Pressure psi (bar)	Fluid Inlet NPT (F) in	Fluid Outlet
<b>METERED, RIGID NOZZLE MODELS</b>					
635390-11	4 (15)	pt / gal	1,000 (69)	1/2"	Non-drip tip
635390-22	4 (15)	qt / gal	1,000 (69)	1/2"	Non-drip tip
635390-33	4 (15)	L / L	1,000 (69)	1/2"	Non-drip tip
<b>NON-METERED, RIGID NOZZLE MODELS (HANDLE AND NOZZLE ONLY)</b>					
635391-11	4 (15)	N/A	1,000 (69)	1/2"	Non-drip tip
<b>METERED, FLEXIBLE NOZZLE MODELS</b>					
635390-1	4 (15)	pt / gal	1,000 (69)	1/2"	Non-drip tip
635390-2	4 (15)	qt / gal	1,000 (69)	1/2"	Non-drip tip
635390-3	4 (15)	L / L	1,000 (69)	1/2"	Non-drip tip
<b>NON-METERED, FLEXIBLE NOZZLE MODELS (HANDLE AND NOZZLE ONLY)</b>					
635391-1	4 (15)	N/A	1,000 (69)	1/2"	Non-drip tip
<b>METER ONLY</b>					
635190-1	4 (15)	pt / gal	1,000 (69)	1/2"	
635190-2	4 (15)	qt / gal	1,000 (69)	1/2"	
635190-3	4 (15)	L / L	1,000 (69)	1/2"	
<b>METER, CONTROL HANDLES (W/OUT NOZZLES)</b>					
635390-10	4 (15)	pt / gal	1,000 (69)	1/2"	
635390-20	4 (15)	qt / gal	1,000 (69)	1/2"	
635390-30	4 (15)	L / L	1,000 (69)	1/2"	

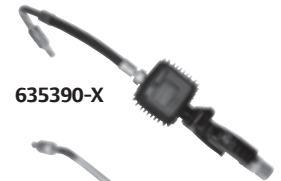

635390-X



635390-XX



635391-11



635391-1



635190-X

Order protective boot 74066 separately.



## Metered Fluid Control Handles

Model	Units of Measure	Totalizing Increments	Working Pressure psi	Inlet Size in	Fluid Outlet
<b>PRESET, DIGITAL METERED FLOW CONTROL</b>					
Preset unit automatically shuts off when set quantity of fluid is delivered and meter indicator returns to zero. Totalizer registers up to 9,999 units.					
635360-2	Quarts	Gallons	1,000 (69)	1/2"	Non-drip flex extension
635360-22	Quarts	Gallons	1,000 (69)	1/2"	Non-drip rigid extension
635360-3	Liters	Liters	1,000 (69)	1/2"	Non-drip flex extension
635360-33	Liters	Liters	1,000 (69)	1/2"	Non-drip rigid extension
<b>PRESET, METERED FLOW CONTROL</b>					
Preset unit automatically shuts off when set quantity of fluid is delivered and meter indicator returns to zero. Totalizer registers up to 9,999 units.					
635364	Quarts, from 1 to 60	Gallons	1,000 (69)	1/2"	Non-drip tip, 9/16" diameter
635365	Gallons, from 1 to 60	Gallons	1,000 (69)	1/2"	Non-drip tip, 9/16" diameter
635367	Liters, from 1 to 60; auto shut off	Liters	1,000 (69)	1/2"	Non-drip tip, 9/16" diameter



635360-2



635365

## Non-drip Nozzle / Hose

Model	Description	Fluid Inlet NPT (M) in	Length in (mm)	Max Working Pressure psi (bar)
<b>MOTOR OIL, GEAR OIL, TRANSMISSION FLUID</b>				
629212	Non-drip nozzle / hose	3/4"	12" (305)	900 (62)
629226	Non-drip nozzle / hose	1/2"	11" (279)	900 (62)
629516	Non-drip nozzle / hose	1/2"	13" (330)	1,000 (69)
629521	Right-angle nozzle / hose	1/2"	15" (381)	1,000 (69)
6786	Right-angle, rigid, non-drip nozzle	1/4"	6-1/2" (165)	1,000 (69)
60798	Rigid, non-drip nozzle	1/2"	5-1/2" (133)	1,000 (69)
<b>NOZZLE, FLEXIBLE HOSE, WITH NON-DRIP TIP</b>				
629245-1	Flexhose, non-drip tip	1/2"	15" (381)	1,000 (69)
<b>NOZZLE, RIGID TUBE, WITH NON-DRIP TIP</b>				
629245-2	Rigid tube, non-drip tip	1/2"	13" (330)	1,000 (69)



629226



629516



629521



6786

## High-pressure Grease Control Handles

Model	Description	Max Working Pressure psi (bar)	Fluid Inlet NPT (F) in	Fluid Outlet in
<b>GREASE CONTROL HANDLES</b>				
636101	Dispenses lubrication at line pressure for lubricating grease fittings. Does not include nozzle or hydraulic coupler. For applications requiring high-flow capacity. Remove the 1/8" (M) x 3/8" (M) adaptor for 3/8" (F) porting.	7,500 (517)	3/8" (F)	11/16 - 16" (M) or 1/8" NPT (F)
636111	Dispenses lubricant at line pressure for lubricating grease fittings. Includes inlet material filter and curved nozzle with hydraulic coupler. Remove the 1/8" (M) x 3/8" (M) adaptor for 3/8" (F) porting.	7,500 (517)	1/8" (M) or 3/8" (F)	Hydraulic coupler
636103	High-pressure booster handle delivers line pressure for normal lubrication. Trigger booster feature delivers 10,000 psi (689 bar) to break loose tougher fittings. Includes curved nozzle with hydraulic coupler, inlet material filter and manual pressure vent for easy disconnection. <b>WARNING: Do not use with whip hose.</b>	7,500 (517)	1/8" (M) or 3/8" (F)	Hydraulic coupler
<b>WHIP HOSES FOR GREASE CONTROL HANDLES*</b>				
629742	Extra-long, wire braid (624201-02) whip hose with hydraulic coupler and swivel. Overall length 29-1/2" (749 mm). For use with coupler 636111 high-pressure control handle. Allows operator to access hard-to-reach fittings.	5,000 (345)	1/8" (F)	hydraulic

\*WARNING: Not for use with 636103 high-pressure booster handle.



636101

636111



636103



629742

## Water, Anti-freeze, Windshield Fluid Control Handle

Model	Description
<b>WATER, ANTI-FREEZE, WINDSHIELD FLUID</b>	
635129	Fluid dispensing nozzle — 635129 bib with trigger 1/4" NPTF inlet, zinc die casting with brass and nitrile seals for water or oil service; radiator type bib has 1/4" fluid inlet and non-drip tip



635129

## Hand-operated Pumps

### Grease NLGI #0 thru #3

Model	Description
<b>LUBRICATION PUMPS, 35-LB, DRUM COVER TYPE</b>	
611016	Ball joint lubricator — Can deliver up to 1/4-oz of lubricant per stroke. Includes 72006 drum cover, 622511-10 hose assembly, 640095-3-B follower plate and 72806 booster control handle. Control handle capable of generating up to 7,500 psi.



**611016**

### Motor Oil, Gear Oil, Transmission Fluid

Model	Ratio	Description
<b>MOTOR OIL, GEAR OIL, TRANSMISSION FLUID</b>		
<b>5-GAL</b>		
611170	Adjustable	Capable of high-volume delivery. Includes 621597-5 hose / dispensing, 2:1, 4:1, 7:1 nozzle assembly (5' (1.5 m), 1/2" ID hose) and 72006 drum cover.



**611170**

Container not included.

# Accessories



Ingersoll Rand offers an extensive line of accessories to match your tools with the requirements of every job. These accessories put the reliability and quality of Ingersoll Rand behind every job you do. For a comprehensive listing of all Ingersoll Rand accessories, please go to [ingersollproducts.com/accessories](http://ingersollproducts.com/accessories)

## ARO Flo Series

For more than 100 years, Ingersoll Rand ARO has been an industry leader in the design and manufacture of compressors, pneumatic tools, and air preparation equipment. Clean air is a key ingredient that enables effective and efficient operation of tools, equipment, and machinery in almost every industry. As such, the use of air preparation devices, such as filters, regulators, and lubricators (FRLs) is an excellent means of keeping your air supply in top condition, as well as enabling your tools and equipment to operate at their peak performance. The new ARO-Flo Series FRLs continue the tradition of offering premium products for your operation, and also raises the bar in the industry for safety, flow performance, and modularity.

### Filters

Part Number	NPT in	Flow Rate scfm	Bowl Capacity oz	Bowl Type	Weight lb
<b>FILTERS</b>					
F35111-420	1/8"	38	0.4	Composite Nylon	0.36
F35121-420	1/4"	49	0.4	Composite Nylon	0.36
F35221-410	1/4"	73	1.3	Metal	0.75
F35331-410	3/8"	107	1.3	Metal	1.44
F35341-410	1/2"	197	2.4	Metal	1.42
F35451-410	3/4"	288	5.3	Poly	2.77

#### Features

- Pipe sizes from 1/8" to 1" NPT
- Flows to 325 cfm
- Maximum inlet pressures to 250 psig



F35341-410

### Lubricators

Part Number	NPT in	Flow Rate scfm	Bowl Capacity oz	Bowl Type	Weight lb
<b>LUBRICATORS</b>					
L36111-120	1/8"	32	0.7	Composite Nylon	0.38
L36121-120	1/4"	51	0.7	Composite Nylon	0.38
L36221-110	1/4"	51	1.5	Metal	0.74
L36331-110	3/8"	105	1.5	Metal	1.48
L36341-110	1/2"	156	3.7	Metal	1.46

#### Features

- Pipe sizes from 1/8" to 1" NPT
- Flows to 440 cfm
- Maximum inlet pressures to 250 psig



L36341-110

### Regulators

Part Number	NPT in	Flow Rate cfm	Adjusted Pressure Range psi	Weight lb
<b>REGULATORS</b>				
R37111-600	1/8"	45	0-140	0.43
R37121-600	1/4"	59	0-140	0.42
R37221-600	1/4"	86	0-140	0.87
R37331-600	3/8"	113	0-140	1.15
R37341-600	1/2"	210	0-140	1.19
R37451-600	3/4"	290	0-140	3.34

#### Features

- Pipe sizes from 1/8" to 1" NPT
- Flows to 491 cfm
- Maximum inlet pressures to 300 psig



R37-221-600

## Accessories

Part Number	Port Size (F) NPT in	Flow Rate cfm	Bowl Size oz	Weight lb
<b>IN-LINE LUBRICATOR</b>				
L01-02-000	1/4"	36	0.25	0.2
L01-03-000	3/8"	38.1	0.25	0.2



### Features

- Assure proper lubrication for small pneumatic hand tools
- Oil capacity is 0.25 oz
- Requires cyclical or intermittent airflow for proper operation
- Cannot be filled under pressure

## Piggyback Combination Over / Under Filters

Part Number	NPT in	Flow Rate cfm	Bowl Size oz	Filter Element micron	Bowl Type	Adjusted Pressure Range psig	Weight lb
<b>PIGGYBACK COMBINATION FILTERS</b>							
P39114-620	1/8" mini	13	1.1	20	Composite nylon	5 - 125	2.05
P39124-620	1/4" mini	13	1.1	40	Composite nylon	5 - 125	2.03
P39224-610	1/4"	93	6	40	Metal	5 - 125	2.05
P39334-610	3/8"	135	6	40	Metal	5 - 125	2.03
P39344-610	1/2"	140	6	40	Metal	5 - 125	2



## Combination Filters

Part Number	NPT in	Flow Rate cfm	Bowl Size oz	Filter Element micron	Bowl Type	Adjusted Pressure Range psig	Weight lb
<b>COMBINATION FILTERS</b>							
C38121-820	1/4" mini	13	1.1	20	Composite nylon	5 - 125	1.2
C38121-620	1/4" mini	13	1.1	20	Composite nylon	5 - 125	1
C38221-610	1/4"	75	6	40	Metal with sight glass	5 - 125	5.48
C38221-810	1/4"	54	6	40	Metal with sight glass	5 - 125	6.98
C38331-610	3/8"	100	6	40	Metal with sight glass	5 - 125	5.43
C38331-810	3/8"	100	6	40	Metal with sight glass	5 - 125	6.35
C38341-610	1/2"	110	6	40	Metal with sight glass	5 - 125	6.38
C38341-810	1/2"	110	6	40	Metal with sight glass	5 - 125	6.69

Regulators / lubricators with gauge.



## Liquidator™ Filters / Dryers

Part Number	NPT in	Description	Flow Rate cfm
<b>FILTERS</b>			
TS-4000	1/2"	Liquidator tool saver	60
EAD-6000	1/2"	Liquidator prep station air dryer	60
PDS-2000	1/2"	Liquidator paint booth dessicant dryer	25

Part Number	Stage	Used In	Quantity
<b>REPLACEMENT ELEMENTS</b>			
8844-060	One	EAD-6000	1
8844-060C	Two	EAD-6000	1
8844-460	One	PDS-2000	1
8844-DES	Two	PDS-2000	1
8844-DES-6	Two	PDS-2000	6
8844-060	One and two	TS-4000	1

### Features

- Centrifugal spinning
- Stainless steel media
- Friction drying and filtered air to one micron
- Inverse flow
- Automatic drain



## Ingersoll Rand Lubricants

It goes without saying that proper lubrication of any tool is essential if you want the tool to last. By lubricating your air tools, you'll prolong the life of tool motors, governors, clutches, and other important impact mechanisms. Ingersoll Rand offers a complete line of specialized oils and greases to complement our full line of air tools.

### Air Care Kits

Part Number	Description
<b>AIR CARE KITS</b>	
67-LBK1	Angle grinder care kit includes 10Z4 oil, 4 oz 67 grease, grease gun
105-LBK1	Metallic housings Impactool care kit includes 10Z4 oil, 4 oz 105 grease, grease gun
115-LBK1	Composite housings Impactool care kit includes 10Z4 oil, 4 oz 115 grease, grease gun



105-LBK1

### Air Tool Oils

Part Number	Description	Size
<b>AIR TOOL OILS</b>		
63Z4	#63 oil for Cyclone wick lubrication	4 oz
10Z4	Class 1 #10 oils for use with percussive, assembly, Impactool	4 oz
10G	Class 1 #10 oils for use with percussive, assembly, Impactool	1 gal
10P	Class 1 #10 oils for use with percussive, assembly, Impactool	1 pt
10G55	Class 1 #10 oils for use with percussive, assembly, Impactool	55 gal
50P	Class II lubricant, #50 oil for use with grinders, Impactool, hoists, winches	1 pt
50G	Class II lubricant, #50 oil for use with grinders, Impactool, hoists, winches	1 gal
62 1 Gal	Class II #62 oil for hoist and winch gear boxes	1 gal



10Z4



10G



10P



LUB-POP

Accessories

## Greases

Part Number	Description	Grease #	Size
<b>GREASES</b>			
23-1 LB	For the gearing of drills	23	1 lb
28 1 LB	For screwdriver gearing and clutches; drills, grinders, saws; tie tampers grease	28	1 lb
66 1 LB	For slow-speed, high-torque angle heads	66	1 lb
66 8 LB	For slow-speed, high-torque angle heads	66	8 lb
67-4T	For high-speed, high-temp angle heads (green)	67	4 oz
67-1 LB	For high-speed, high-temp angle heads (green)	67	1 lb
67 8 LB	For high-speed, high-temp angle heads (green)	67	8 lb
70 1 LB	For large piston motors and gear cases	70	1 lb
70 8 LB	For large piston motors and gear cases	70	8 lb
77-1 LB	For grinder angle heads	77	1 lb
80 1 LB	For bearings on sump pumps	80	1 lb
80 8 LB	For bearings on sump pumps	80	8 lb
90-14 oz	For gear heads and tube nut wrenches	90	14 oz
100 1 LB	Standard-duty Impactool grease	100	1 lb
100 8 LB	Standard-duty Impactool grease	100	8 lb
105-4T-6	Metallic housing Impactool grease	105	4 oz
105-1 LB	Metallic housing Impactool grease	105	1 lb
105-8 LB	Metallic housing Impactool grease	105	8 lb
115-4T-6	Composite housing Impactool grease	115	4 oz
115-1 LB	Composite housing Impactool grease	115	1 lb
150-1 LB	For impact mechanisms with swinging weight	150	1 lb
150-8 LB	For impact mechanisms with swinging weight	150	8 lb
170-1 LB	Premium impact grease for high temps, used with impact mechanisms	170	1 lb



100 1 LB



105-4T-6

## Lubrication Kits

Part Number	Description	Quantity
<b>LUBRICATION KITS</b>		
LUB-POP	Point-of-purchase display includes (3) 10G, (5) 10P, (24) 10Z4, (6) 100-1LB, (8) 105-LBK1, (8) 115-LBK1, (1) case 10Z4, (1) case hang tags	1
10Z4-MB24	Case of 10Z4; countertop display	24
10P-MB5	Case of 10P; countertop display	5
10G-MB3	Case of 10G; countertop display	3
100-MB6	Case of #100 grease; countertop display	6
105LBK1-MB8	Case of 105-LBK1; countertop display	8
115LBK1-MB8	Case of 115-LBK1; countertop display	8



## Grease Guns and Accessories

Part Number	Description
<b>GREASE GUNS</b>	
P25-228	Push-type hand grease gun for hydraulic-type fittings, holds up to 3 oz of grease
R000A2-228	Push-type hand grease gun for flush-type fittings, holds up to 3 oz of grease
<b>GREASE TUBE HEAD</b>	
GTH-1	Grease gun used with Ingersoll Rand 4 oz tube of grease
<b>GREASE GUN COUPLERS</b>	
636020	Grease gun coupler
636024	Grease gun adaptor



P25-228



GTH-1



636020

# MS Series Plugs and Couplers

## INDUSTRIAL INTERCHANGE

- Economical automatic-type, one-way shutoff coupler
- Easy, push-to-connect use

Body Size in	NPT or Hose Stem ID in	Average Flow cfm*	NPT Part Number	Hose Stem ID Part Number
<b>FEMALE PLUGS</b>				
1/4"	1/8"	36	MSPF21	N/A
1/4"	1/4"	36	MSPF22	MSPH22
1/4"	3/8"	36	MSPF23	MSPH23
3/8"	1/4"	67	MSPF32	N/A
3/8"	3/8"	67	MSPF33	MSPH33
3/8"	1/2"	67	45ATH	MSPH34
1/2"	3/8"	126	MSPF43	N/A
1/2"	1/2"	126	MSPF44	MSPH44
1/2"	3/4"	126	MSPF46	N/A
<b>MALE PLUGS</b>				
1/4"	1/8"	36	MSPM21	N/A
1/4"	1/4"	36	MSPF22	MSPH22
1/4"	3/8"	36	MSPM23	MSPH23
3/8"	1/4"	67	MSPM32	N/A
3/8"	3/8"	67	PRPM33	MSPH33
3/8"	1/2"	67	MSPM34	MSPH34
1/2"	3/8"	126	MSPM43	N/A
1/2"	1/2"	126	MSPM44	MSPH44

\*At 90 psig inlet and 10 psig pressure drop.

### Female Plugs



Female NPT



Hose Stem ID



45ATH

### Male Plugs



Male NPT



Hose Stem ID

Body Size in	NPT or Hose Stem ID in	Average Flow cfm*	Manual NPT Part Number	Automatic NPT Part Number	Hose Stem ID Part Number
<b>FEMALE COUPLERS</b>					
1/4"	1/4"	36	N/A	MSCF22	MSCH22
1/4"	3/8"	36	N/A	MSCF23	MSCH23
3/8"	3/8"	67	420ATH	MSCF33	MSCH33
3/8"	1/2"	67	440ATH	N/A	N/A
1/2"	1/2"	126	N/A	MSCF44	MSCH44
<b>MALE COUPLERS</b>					
1/4"	1/4"	36	N/A	MSCM22	MSCH22
1/4"	3/8"	36	N/A	MSCM23	MSCH23
3/8"	1/4"	67	N/A	4100ATH	N/A
3/8"	3/8"	67	430ATH	MSCM33	MSCH33

### Female Couplers



Automatic NPT



Hose Stem ID



Manual NPT

### Male Couplers



Automatic NPT



Hose Stem ID



4100ATH



430ATH

## PR Series Plugs and Couplers

Body Size in	NPT in	Average Flow cfm*	Part Number
<b>FEMALE THREAD COUPLERS</b>			
1/4"	1/4"	32	PRSGF22
1/4"	3/8"	32	PRSGF23
3/8"	3/8"	64	PRSGF33
3/8"	1/2"	64	PRSGF34
1/2"	3/8"	147	PRSGF43
1/2"	1/2"	147	PRSGF44
1/2"	3/4"	147	PRSGF46
<b>MALE THREAD COUPLERS</b>			
1/4"	1/4"	32	PRSGM22
1/4"	3/8"	32	PRSGM23
3/8"	3/8"	64	PRSGM33
3/8"	1/2"	64	PRSGM34
1/2"	3/8"	147	PRSGM43
1/2"	1/2"	147	PRSGM44
1/2"	3/4"	147	PRSGM46
<b>HOSE BARB COUPLERS</b>			
1/4"	1/4"	32	PRSGH22
3/8"	1/4"	32	PRSGH23
3/8"	3/8"	64	PRSGH33
1/2"	3/8"	64	PRSGH34
3/8"	1/2"	147	PRSGH43
1/2"	1/2"	147	PRSGH44
5/8"	1/2"	147	PRSGH45
3/4"	1/2"	147	PRSGH46

\*At 90 psig inlet and 10 psig pressure drop.

### QUICK CONNECT DOUBLE-ACTION COMPOSITE SAFETY COUPLERS

#### Couplers

- Made of non-marring composite
- Safety coupler eliminates accidental disconnects
- Easy connect, disconnect
- Allows you to bleed hoses
- Shockproof and crush-resistant



Hose Barb Couplers



Female Thread Couplers



Male Thread Couplers

Body Size in	NPT in	Average Flow cfm*	Part Number
<b>FEMALE THREAD CONNECTOR PLUGS</b>			
1/4"	1/4"	N/A	PRPF22
1/4"	3/8"	N/A	PRPF23
3/8"	1/4"	N/A	PRPF32
3/8"	3/8"	N/A	PRPF33
1/2"	1/2"	N/A	PRPF44
<b>MALE THREAD CONNECTOR PLUGS</b>			
1/4"	1/4"	N/A	PRPM22
1/4"	3/8"	N/A	PRPM23
3/8"	1/4"	N/A	PRPM32
3/8"	3/8"	N/A	PRPM33
<b>HOSE BARB CONNECTOR PLUGS</b>			
1/4"	1/4"	32	PRPH22
3/8"	1/4"	32	PRPH23
3/8"	3/8"	64	PRPH33
1/2"	3/8"	64	PRPH34
1/2"	1/2"	147	PRPH44
5/8"	1/2"	147	PRPH45
3/4"	1/2"	147	PRPH46

\*At 90 psig inlet and 10 psig pressure drop.

#### Connector Plugs

- Carbonitride steel with anti-corrosion protection
- Teflon coating on all male threads



Female Thread Connector Plugs



Male Thread Connector Plugs



Hose Barb Connector Plugs

## Air Hose Nipples

Part Number	Hose Size in (mm)	Pipe Thread in
<b>MALE PIPE THREAD</b>		
IR78217	1/4" (6)	1/4"
IR30127	5/16" (8)	1/4"
AL-387	5/16" (8)	3/8"
R00-146	3/8" (10)	1/8"
D01-14	3/8" (10)	1/4"
IR6225	3/8" (10)	3/8"
A01-46	1/2" (13)	3/8"
D02-455	1/2" (13)	1/2"
A03-46	3/4" (19)	1/2"
J3-581	3/4" (19)	3/4"
P35-46	1" (25)	1"
CN-20-S	2" (51)	2"
<b>FEMALE PIPE THREAD</b>		
R1-47	5/16" (8)	3/8"
R00-147	3/8" (10)	3/8"

### Male Pipe Thread



AL-387



R00-146



D01-14



IR6225



A01-46



A03-46

### Female Pipe Thread



R00-147

## Swivels and Adapters

Part Number	Thread Size in	Airflow cfm*	Description
<b>SWIVEL-IT SWIVELS</b>			
ASA-1/4	1/4"	0 - 25	Adjustable Swivel-It
ASC-1/4	1/4"	0 - 33	Non-marring Swivel-It
AS-3/8	3/8"	0 - 45	Standard Swivel-It
AS-1/2	1/2"	0 - 65	Standard Swivel-It

Part Number	Size NPT in	Description
<b>SWIVELS AND ADAPTERS</b>		
636077	1/8" (M) x 1/8" (F)	Z swivel
636086-B	1/4" (M) x 1/4" (F)	Z swivel
636087-B	1/4" (M) x 1/4" (F) with filter element	Z swivel
635106	1/2" (F) x 3/8" (M)	Z swivel
636075	1/8" (M) x 1/8" (F)	Straight swivel
636085	3/8" (M) x 3/8" (F)	Straight swivel
635117	1/2" (M) x 1/2" (F)	Straight swivel
635108	3/4" (M) x 3/4" (F)	Straight swivel
635107	3/8" (M) x 1/2" (F)	Straight swivel
3249	1/8" (F) x 1/8" (F)	Female adapter
676	1/8" (M) x 1/8" (M)	Male adapter

### Swivel-It Swivels



ASC-1/4

### Swivels and Adapters



636077



636075



635108



676

## Hose Whips

Part Number	Hose ID in	Hose Length ft	Male End in	Female End in
<b>HOSE WHIPS*</b>				
R00H-130	1/4"	8'	1/8"	1/4"
R0-130	5/16"	8'	1/4"	3/8"
R1A-130	3/8"	8'	1/4"	3/8"
510-130	3/8"	8'	3/8"	3/8"

\*250 psig max working pressure.

Consists of hose assembled with male hose nipple at one end and female hose nipple at the other end.



R00H-130

## Fitting Kits — Polyurethane Coil Hoses

Part Number	Description
<b>FITTING KITS*</b>	
P14-RMS	1/4" NPT reusable male swivel fitting kit for 1/4" ID polyurethane hose
P38-RMS	3/8" NPT reusable male swivel fitting kit for 3/8" ID polyurethane hose
P14-RMR	1/4" NPT reusable male rigid fitting kit for 1/4" ID polyurethane hose
P38-RMR	3/8" NPT reusable male rigid fitting kit for 3/8" ID polyurethane hose
P12-RFR	1/2" NPT reusable female rigid fitting kit for 1/2" ID polyurethane hose
P12-RMS	1/2" NPT reusable male rigid fitting kit for 1/2" ID polyurethane hose

\*125 psig working pressure @ 75° F.



P38-RMS



P12-RMS



P38-RMR

## Premium Rubber Hose

Part Number	Size
<b>PREMIUM RUBBER HOSE</b>	
38016820	3/8" x 50'

- Premium rubber air hose, specifically designed for heavy-duty applications, such as industrial, maintenance, automotive, and/or construction
- 3/8" x 50' red hose with black Ingersoll Rand logo
- Black hose restrictors on each end provide a 300 psi working pressure and a 4:1 safety burst ratio

## Polyurethane Coil Hoses

Part Number	Description
<b>POLYURETHANE COIL HOSES</b>	
P14-10	1/4" x 10' polyurethane coil hose, (1) 1/4" rigid, (1) 1/4" swivel fitting
P14-20	1/4" x 20' polyurethane coil hose, (1) 1/4" rigid, (1) 1/4" swivel fitting
P14-30	1/4" x 30' polyurethane coil hose, (1) 1/4" rigid, (1) 1/4" swivel fitting
P38-10	3/8" x 10' polyurethane coil hose, (1) 3/8" rigid, (1) 3/8" swivel fitting
P38-20	3/8" x 20' polyurethane coil hose, (1) 3/8" rigid, (1) 3/8" swivel fitting
P38-30	3/8" x 30' polyurethane coil hose, (1) 3/8" rigid, (1) 3/8" swivel fitting
P12-10R	1/2" x 10' polyurethane coil hose, (2) 1/2" reusable swivel fittings
P12-20R	1/2" x 20' polyurethane coil hose, (2) 1/2" reusable swivel fittings
P12-30R	1/2" x 30' polyurethane coil hose, (2) 1/2" reusable swivel fittings

### Features

- Superior elasticity and coil memory mean a cleaner work environment
- Outstanding flexibility increases operator comfort
- 25% lighter than rubber hose, reducing operator fatigue
- Abrasion and kink resistance increase lifetime
- Tight coil diameter allows easy entry into confined spaces
- Non-marring surface won't harm work pieces
- Broad chemical resistance makes hoses suitable for most environments
- Better than 80% working length extends your work space
- Straight tails on both ends eliminate workstation tangles
- Reusable MNPT fittings allow field retrofits
- Thread sealant on all fittings provides for leak-free joints



### Features

- 6-year warranty
- Longer life than PVC
- Reinforced innermost tube, resistant to the materials it is intended to convey
- Extended life bend restrictors
- Increased flexibility in cold temperatures
- Designed to withstand the harshest jobsite conditions
- Extended service life due to number of threads, spirals, and thickness of rubber tube



## Spring Balancers

- 19 models to choose from
- Three different series to meet all balancing requirements
- Lifts ranging from 4-1/4' to 8.2'
- Covers weight balancing needs from 1 to 30 lb
- Made of rugged die-cast aluminum
- Safety locking device in case of spring breakage on medium-duty models
- Easy-to-use controls allow for accurate spring adjustment

## Hose Reel Balancers

Part Number	Hose Nipple Size in	Extended cfm	Capacity lb (kg)	Lift ft (mm)
<b>HOSE REEL BALANCERS</b>				
BHR-8	1/4"	18.4	0.875 - 1.75 (0.397 - 0.794)	4-1/4' (1295)
BHR-15	1/4"	18.4	1.5 - 3.33 (0.68 - 1.51)	4-1/4' (1295)
BHR-25	1/4"	18.4	2.625 - 5.5 (1.191 - 2.495)	4-1/4' (1295)

### Hose Reel Balancers



BHR-15

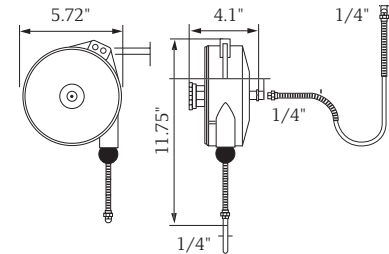

BHR Series

## Light-duty Balancers

Part Number	Capacity lb (kg)	Weight Of Balancer lb (net-kg)	Lift ft (mm)
<b>LIGHT-DUTY BALANCERS — 0.9 - 6.6 LB CAPACITY</b>			
BLD1	0.9 - 2.2 (0.4 - 1)	1.3 (0.6)	5.2' (1600)
BLD2	2.2 - 4.4 (1 - 2)	1.3 (0.6)	5.2' (1600)
BLD3	4.4 - 6.6 (2 - 3)	1.3 (0.7)	5.2' (1600)

### Light-duty Balancers



BLD1

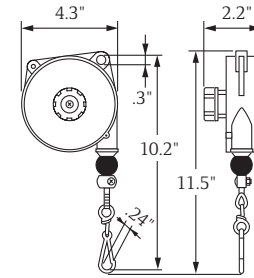

BLD Series

- Rotary hook
- Adjustable capacity and stroke limiting device
- Self-lubricating bushings
- Auxiliary safety suspension

## Medium-duty Balancers

Part Number	Capacity lb (kg)	Weight of Balancer lb (net-kg)	Lift ft (mm)
<b>MEDIUM-DUTY BALANCERS* SHORT CABLES</b>			
BMDS-2	2.2 - 5.5 (1 - 2.5)	4.4 (2)	6.5' (2000)
BMDS-4	4.4 - 8.8 (2 - 4)	4.4 (2)	6.5' (2000)
BMDS-6	8.8 - 13.2 (4 - 6)	5.1 (2.3)	6.5' (2000)
BMDS-8	13.2 - 17.6 (6 - 8)	5.5 (2.5)	6.5' (2000)
<b>LONG CABLES</b>			
BMDLN-4	4.4 - 8.8 (2 - 4)	6.4 (2.9)	8.2' (2500)
BMDLN-6	8.8 - 13.2 (4 - 6)	7.1 (3.2)	8.2' (2500)
BMDLN-8	13.2 - 17.6 (6.8 - 8)	7.7 (3.5)	8.2' (2500)
BMDLN-10	17.6 - 22 (8 - 10)	8.2 (3.7)	8.2' (2500)
BMDLN-12	22 - 30 (10 - 14)	8.8 (4)	8.2' (2500)
<b>MEDIUM-DUTY LOCKING BALANCERS* LONG CABLES</b>			
BMDLLN-4	4.4 - 8.8 (2 - 4)	6.6 (3)	8.2' (2500)
BMDLLN-6	8.8 - 13.2 (4 - 6)	7.3 (3.3)	8.2' (2500)
BMDLLN-8	13.2 - 17.6 (6 - 8)	7.9 (3.6)	8.2' (2500)
BMDLLN-10	17.6 - 22 (8 - 10)	8.4 (3.8)	8.2' (2500)

### Medium-duty Balancers



BMDS-2

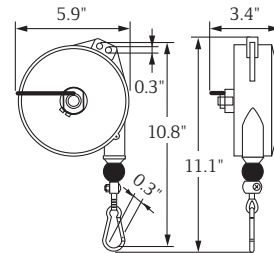

BMDS Series

### Medium-duty Locking Balancers



BMDLLN-10

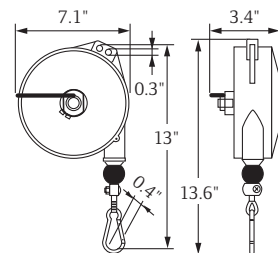

BMDLN / BMDLLN Series

\*Larger sizes available upon request.

# Pullers and Hoists

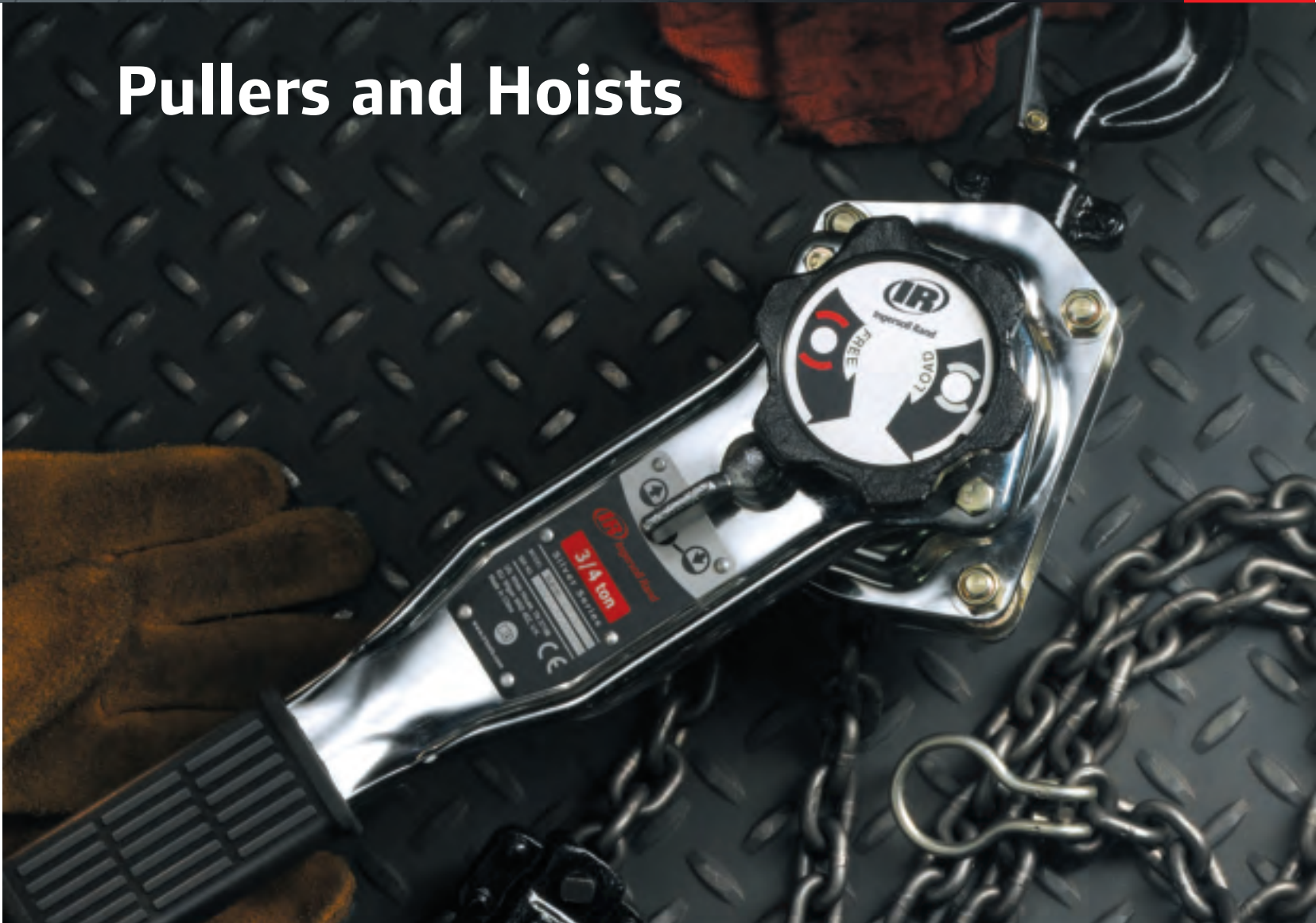

Ingersoll Rand pullers and hoists are designed to handle the tough pulling or lifting jobs, with minimal effort by the operator. Whether it's a low-, medium-, or heavy-duty job, you can trust our pullers and hoists to carry the load safely and easily.



## P-Series Pullers

They'll pull up to 2,000 lb with no problem — and there's no hard work for you, either. Extremely strong and well-made, the Ingersoll Rand P-Series are high-quality, dependable wire rope pullers for low- and medium-duty pulling and lifting jobs.

- Made for superior strength with a steel frame and handle, alloy steel load hook, 1-piece cast aluminum drum, and solid steel drive and holding dog
- 4:1 design factor for lifting or pulling
- Long-lasting gears through the extra heavy Ingersoll Rand buttress tooth design

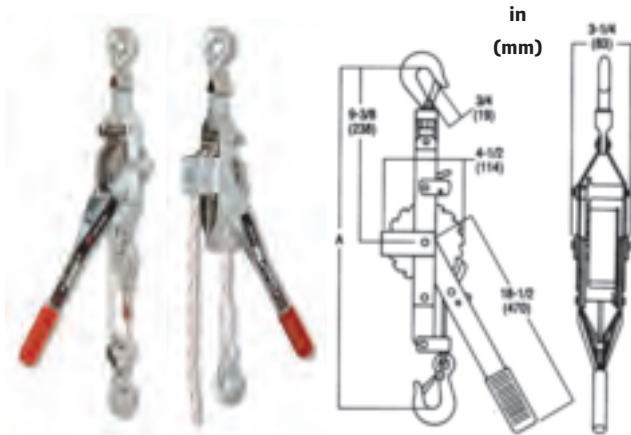

P-Series Pullers

## C-Series Pullers

The C-Series includes rugged cast aluminum wire rope pullers designed to store more wire rope than all-steel ratchet pullers. With a rigged double line, they handle those long reach pulling or lifting jobs up to 3,400 lb with no problem.

- Extremely strong, with a solid cast steel drive and holding dog
- Heavy-duty cast aluminum drum and lightweight aluminum frame, alloy steel load hook with safety latches

Safe lowering is assured by the ratchet and pawl system. The gear teeth use the Ingersoll Rand buttress tooth design for additional strength and longer gear life.

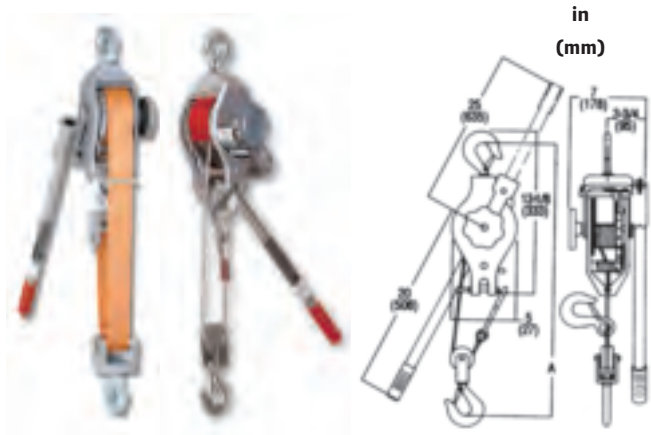

C-Series Pullers

Model	Rated Number of Lines	Min Distance Capacity lb	Lifting Between Hooks in	Distance ft	Cable Diameter in	Net Number of Hooks	Weight lb
<b>P-SERIES PULLERS</b>							
P15HA	Single	1,000	19.5"	15'	3/16"	2	8.5
P15D3HA	Single	1,000	21"	15'	3/16"	3	10.5
	Double	2,000	27.5"	7-1/2'	3/16"	3	10.5
C400HA	Single	1,700	17"	20'	1/4"	3	16
	Double	3,400	22"	10'	1/4"	3	16
C400SA	Single	2,000	17"	12'	3/32" x 1-7/8"	2	16
	Double	4,000	22"	6'	3/32" x 1-7/8"	3	16



## PT-8 Trolley Series

### Plain 1/2 to 5 Metric Ton

Our plain trolley is rated for both manual or powered hoists, and has the versatility to fit most types of beams.

#### Standard features

- The 5:1 design factor allows the PT-8 Series to be used with both manual or powered hoists; meets pertinent U.S. (ASME / ANSI and CMAA), Canadian, and European standards
- The side plates, including the rail sweeps / drop stops, are made of cold-formed steel for strength, durability, and even load distribution
- The wheel axles are rivet-locked in place so they won't come loose — they are not knurled, welded, or modified bolts
- The wheels are cast iron — the universal tread fits both flat and tapered beams



**Suspension bail is supplied with PT-8 trolleys only and is not required for most applications.**

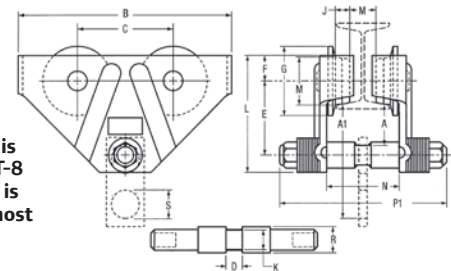

- Wheels run on sealed, "lubed-for-life" ball bearings; smoother rolling with less effort and less maintenance
- Wide hanger shaft assemblies allow PT-8 Series trolleys to fit almost any I beam, H beam, or patented track beam up to 8.06 in (205 mm) wide
- PT-8 Series trolley hanger shafts are designed to accept all hoist brands and have a squared out recess to accept round or squared hook shapes; the trolleys are painted black for universal coordination

Model	Trolley Capacity lb (kg)	Fits Beam Flange Width in (mm)	Beam Height in (mm)	Curve Radius in (mm)	Net Weight lb (kg)
<b>PT-8 TROLLEY CONTRACTOR SERIES — SINGLE 8" (205 MM) HANGER SHAFT</b>					
PT005-8A	1,100 (500)	2.66" – 8.06" (68 – 205)	4" (102)	36" (914)	20 (9)
PT010-8A	2,200 (1000)	3" – 8.06" (76 – 205)	5" (127)	36" (914)	31 (14)
PT020-8A	4,400 (2000)	3.33" – 8.06" (85 – 205)	6" (152)	48" (1219)	61 (28)
PT030-8A	6,600 (3000)	4" – 8.06" (102 – 205)	7" (178)	42" (1067)	73 (33)
PT050-8A	11,000 (5000)	4.66" – 8.06" (118 – 205)	8" (203)	60" (1524)	123 (56)

Model	A in (mm)	A1** in (mm)	B in (mm)	C in (mm)	D in (mm)	E in (mm)	F in (mm)	G in (mm)	H in (mm)
<b>PT-8 TROLLEY DIMENSIONS</b>									
PT005-8A	2.6" (66.0)	5.9" (149.9)	10" (254)	4.5" (114.3)	1" (25.4)	4" (101.6)	1.1" (27.9)	3.5" (88.9)	2.1" (53.3)
PT010-8A	2.5" (63.5)	5.9" (149.9)	13" (330.2)	5.2" (132.1)	1.3" (33.0)	4.4" (111.8)	1.6" (40.6)	4.2" (106.7)	2.8" (71.1)
PT020-8A	2.6" (66.0)	6.1" (154.9)	14.9" (378.5)	6.8" (172.7)	1.3" (33.0)	5.3" (134.6)	1.3" (33.0)	5.8" (147.3)	4.3" (109.2)
PT030-8A	2.6" (66.0)	7.9" (200.7)	14" (355.6)	6.4" (162.6)	1.6" (40.6)	5.5" (139.7)	1.6" (40.6)	5.8" (147.3)	4.5" (114.3)
PT050-8A	2.8" (71.1)	8.1" (205.7)	15.5" (393.7)	7.1" (180.3)	1.6" (40.6)	5.8" (147.3)	2.2" (55.9)	6.2" (157.5)	4.5" (114.3)

Model	J in (mm)	K in (mm)	L in (mm)	M* in (mm)	N* in (mm)	P1** in (mm)	R in (mm)	S in (mm)
<b>PT-8 TROLLEY DIMENSIONS</b>								
PPT005-8A	0.8" (20.3)	0.1" (2.54)	6.6" (167.6)	-	3.9" (99.1)	12.3" (312.4)	1.3" (33.0)	1.6" (40.6)
PT010-8A	0.8" (20.3)	0.1" (2.54)	6.6" (167.6)	-	4.3" (109.2)	12.9" (327.7)	1.5" (38.1)	1.6" (40.6)
PT020-8A	1.1" (27.9)	1.2" (30.5)	7.5" (30.5)	-	4.3" (109.2)	13.8" (350.5)	1.5" (38.1)	1.6" (40.6)
PT030-8A	1.1" (27.9)	1.4" (35.6)	8.6" (218.4)	-	5.4" (137.2)	14.1" (358.1)	1.9" (48.3)	2.6" (66.0)
PT050-8A	1.6" (40.6)	1.4" (35.6)	9.8" (248.9)	-	6.6" (167.6)	15.6" (396.2)	2.5" (63.5)	2.6" (66.0)

\*Minimum dimension.

\*\*Dimension for standard shaft length only.

## Silver Series Lever Chain Hoists

### 3/4 to 6 Metric Ton Lifting Capacity

Meeting ANSI / ASME B30.16 and all pertinent world standards, the “-E” signifies compliance with Europe’s EC95 Machinery Directive.

The patent-pending, arrow-notch free-chain system is simple and reliable. Just one hand turns the indicator, and operators will enjoy the easiest free-chaining we have ever tested. Try to operate a Silver Series hoist in free-chain mode and the brake instantly engages, holding the load and minimizing the risk of an accident. Specify required lift in feet in the “L” position of model number.



Silver Series hoists have a zinc-nickel-chrome-plated finish. It’s more durable and corrosion-resistant than paint. Plus, the Silver Series has the quality features you expect from Ingersoll Rand.

- All-steel construction
- 360° handle rotation
- Rubber handle grip in all sizes
- Reliable disc brake
- Premium-grade alloy chain
- Hardened swivel-latch hooks
- Lightweight
- Low handle force
- Short handle stroke
- Standard lifts of 5, 10, 15, and 2

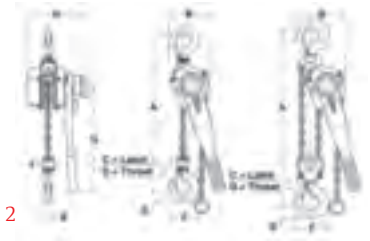

### How to order

Specify required lift in feet in the “L” position of model number.

### Example

SL150-15-A = 3/4 ton, with 15 feet of lift.

Model	Rated Capacity Metric tons	Rated Capacity (lb)	Pull to Lift Rated Load lb	No. of Chain Falls	A mm (in)	B mm (in)	C mm (in)	D mm (in)	E mm (in)	F (min) mm (in)	Ø mm (in)	Load Chain Size mm (in)	
<b>SILVER SERIES CHAIN HOISTS</b>													
SLB150-L-A	3/4	(1,650)	41	1	158 (6.2)	93 (3.6)	132 (5.2)	308 (12.1)	29 (1.1)	330 (13)	37 (1.5)	6 X 18	(0.24 x 0.71)
SLB200 L-A	1	(2,200)	60	1	163 (6.4)	95 (3.7)	140 (5.5)	308 (12.1)	32 (1.3)	365 (14.4)	40 (1.6)	6 X 18	(0.24 x 0.71)
SLB300 L-A (0.28 x 0.84)	1-1/2	(3,300)	53	1	185 (7.3)	106 (4.2)	145 (5.7)	378 (14.9)	35 (1.4)	400 (15.7)	45 (1.8)	7.1 x 21.2	
SLB600 L-A	3	(6,600)	53	1	212 (8.4)	118 (4.6)	199 (7.8)	418 (16.5)	44 (1.7)	520 (20.5)	55 (2.2)	10 x 30	(0.39 x 1.18)
SLB1200 L-A	6	(13,200)	57	2	212 (8.4)	118 (4.6)	230 (9.1)	418 (16.5)	50 (2)	640 (25.2)	65 (2.6)	10 x 30	(0.39 x 1.18)

## SMB Manual Chain Hoists

Ingersoll Rand SMB Silver Series manual chain hoists offer the strength and durability you need in tough lifting situations. Their high-strength, all-stamped steel construction provides decreased weight and better impact resistance. In addition, the hoists feature roller bearings on input shafts and efficient gear reductions for easier lifting. Standard overload protection reduces downtime and repair costs resulting from abuse.

- Efficient gear reductions minimize hand chain overhauled to lift loads
- Encased and retained roller bearings for increased efficiency and ease of maintenance
- Single chain fall through 3 tons
- Nickel / chrome-plated exterior and zinc-plated frame components for increased corrosion resistance
- Double hand chain guides for smooth operation when pulling excess chain
- Open frame design for easy cleaning and inspection
- CE certified; hoists meet or exceed regional requirements including ASME B30.16, HST-2M
- Hardened swivel-latch hooks



**Double load chain guides for proper load-chain tracking and smooth operation around load sheave.**

Silver Series SMB manual chain hoists are ideal for these applications:

- Offshore drilling rigs
- Oil refineries and chemical plants
- Shipbuilding and shipyards
- Mining
- Utilities
- Steel mills and foundries
- General construction
- Maintenance and repairs
- Rigging

**How to order:**

Specify required lift in feet in the "L" position and hand chain length in feet in the "H" position.

**Example:**

10-8VA = 1/2 ton 10 ft lift, 8ft hand chain

Model	Rated Capacity Metric Tons (lb)	No. of Chain Falls	Pull to Lift						Load Chain Size in (mm)	Hoist Net Weight with 10' (3 m) Lift lb
			Rated Load lb	A in (mm)	B in (mm)	C in (mm)	D in (mm)	H (min) in (mm)		
SMB005	1/2 (1,100)	1	55	5.2" (131)	5.4" (137)	1.1" (29)	1.5" (37)	12.8" (325)	0.20" x 0.59" (5 X 15)	23.5
SMB010	1 (2,200)	1	64	5.9" (151)	6" (152.5)	1.3" (32)	1.6" (40)	13.8" (350)	0.24" x 0.71" (6 X 18)	26.8
SMB015	1-1/2 (3,300)	1	69	7" (177)	6.8" (173)	1.4" (35)	1.8" (45)	17.1" (435)	0.26" x 0.83" (7.1 x 21)	38.5
SMB020	2 (4,400)	1	77	7.6" (192)	6.9" (176)	1.6" (40)	2" (50)	18.2" (463)	0.31" x 0.94" (8 x 24.6)	42.4
SMB030	3 (6,600)	1	100	9.4" (238)	8.0" (204)	1.7" (44)	2.2" (55)	20.9" (530)	0.39" x 1.18" (10 x 30)	70.4
SMB050	5 (11,000)	2	83	11.2" (285)	7.4" (188)	2" (50)	2.6" (65)	28" (710)	0.35" x 1.06" (9 x 27.2)	90.2

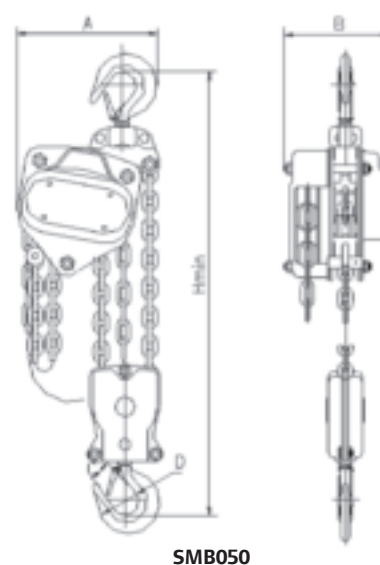
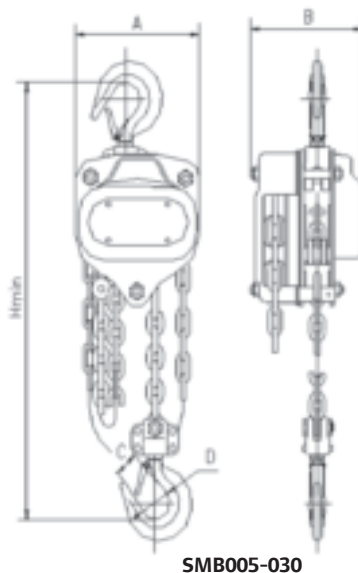

# Index

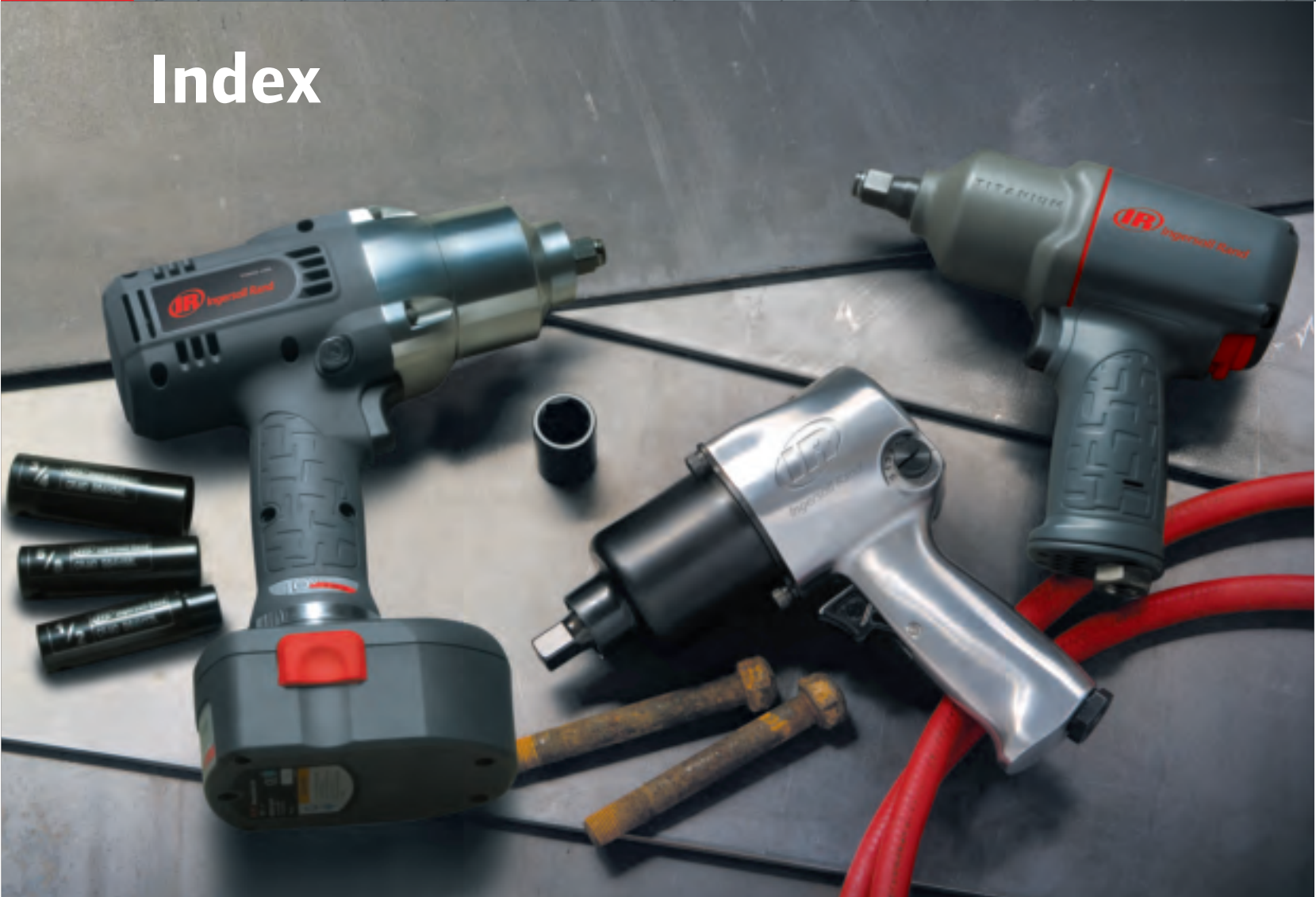

# Index

Model Number	Description	Page
<b>A</b>		
AVC1-83	Beehive Retainer	47
AVC10-183A	Spring Retainer	47
<b>C</b>		
C400HA	P-Series Puller	104
C400SA	P-Series Puller	104
<b>D</b>		
D12IN	Refrigerated Dryer	75
D18IN	Refrigerated Dryer	75
D25IN	Refrigerated Dryer	75
D040	Cordless Drill Driver	57
D42IN	Refrigerated Dryer	75
D54IN	Refrigerated Dryer	75
D72IN	Refrigerated Dryer	75
D108IN	Refrigerated Dryer	75
D144IN	Refrigerated Dryer	75
D180IN	Refrigerated Dryer	75
D300IN	Refrigerated Dryer	75
D360IN	Refrigerated Dryer	75
D550S	Cordless Drill Driver	57
D650S	Cordless Drill Driver	57
<b>F</b>		
F35IG	General Purpose Filter	77
F35IH	High Efficiency Filter	77
F71IG	General Purpose Filter	77
F71IH	High Efficiency Filter	77
F108IG	General Purpose Filter	77
F108IH	High Efficiency Filter	77
F144IG	General Purpose Filter	77
F144IH	High Efficiency Filter	77
F178IG	General Purpose Filter	77
F178IH	High Efficiency Filter	77
F212IG	General Purpose Filter	77
F212IH	High Efficiency Filter	77
F395IG	General Purpose Filter	77
F395IH	High Efficiency Filter	77
F424IG	General Purpose Filter	77
F424IH	High Efficiency Filter	77
<b>G</b>		
GC25	Cut-off Tool	59
GR25	Cordless Angle Grinder	58
GS25	Cordless Straight Grinder	58
<b>L</b>		
LM2203A-11-C	3:1 Piston Pumps	82
LM2203A-31-C	3:1 Piston Pumps	82
LM2203A-41-C	3:1 Piston Pumps	82
LM2203A-51-C	3:1 Piston Pumps	82
LM2250E-21-B	50:1 Piston Pumps	82
LM2250E-31-B	50:1 Piston Pumps	82
LM2250E-41-B	50:1 Piston Pumps	82

Model Number	Description	Page
LM2250E-61-B	50:1 Piston Pumps	82
LM2305A-11-B	5:1 Piston Pumps	82
LM2305A-31-B	5:1 Piston Pumps	82
LM2305A-41-B	5:1 Piston Pumps	82
LM2305A-51-B	5:1 Piston Pumps	82
LM2350E-21-B	50:1 Piston Pumps	82
LM2350E-31-B	50:1 Piston Pumps	82
LP2001-1-B	Grease Pump Packages	83
LP2002-1-B	Grease Pump Packages	83
LP2003-1-B	Grease Pump Packages	83
LP2004-1-B	Grease Pump Packages	83
LP2006-1-B	Grease Pump Packages	83
LP2100-1-B	Portable Oil Pump Package	83
LP3001-1	Grease Pump Packages	83
LP3002-1	Grease Pump Packages	83
LP3003-1	Grease Pump Packages	83
LP3004-1	Grease Pump Packages	83
LP3005-1	Grease Pump Packages	83
LP3007-1	Grease Pump Packages	83
LP3100-1-B	Portable Oil Pump Package	83
<b>P</b>		
P1.5IU-A9	Single Stage Air Compressor	67
P1IU-A9	Single Stage Air Compressor	67
P15D3HA	P-Series Pullers	104
P15HA	P-Series Pullers	104
PD03P-AES-DCC	Diaphragm Pump	85
PD03P-AES-DTT	Diaphragm Pump	85
PD03P-ARS-PCC	Diaphragm Pump	85
PD03P-ARS-PTT	Diaphragm Pump	85
PD05P-AES-DCC-B	Diaphragm Pump	85
PD05P-AES-DTT-B	Diaphragm Pump	85
PD05P-ARS-PAA-B	Diaphragm Pump	85
PD05P-ARS-PCC-B	Diaphragm Pump	85
PD05P-ARS-PTT-B	Diaphragm Pump	85
PF2200-3231	Round Nose Chisel	47
PF2200-3232	Cape Chisel	47
PPT005-8A	Trolley Series	105
PT005-8A	Trolley Series	105
PT010-8A	Trolley Series	105
PT020-8A	Trolley Series	105
PT030-8A	Trolley Series	105
PT050-8A	Trolley Series	105
<b>R</b>		
R140	Cordless Ratchets	58
R145	Cordless Ratchets	58
R380	Cordless Ratchets	58
R385	Cordless Ratchets	58
<b>S</b>		
SLB150-L-A	Silver Series Chain Hoist	106
SLB200 L-A	Silver Series Chain Hoist	106
SLB300 L-A	Silver Series Chain Hoist	106
SLB600 L-A	Silver Series Chain Hoist	106

## Index

Model Number	Description	Page
SLB1200 L-A	Silver Series Chain Hoist	106
SMB005	SBM Manual Chain Hoist	107
SMB010	SBM Manual Chain Hoist	107
SMB015	SBM Manual Chain Hoist	107
SMB020	SBM Manual Chain Hoist	107
SMB030	SBM Manual Chain Hoist	107
SMB050	SBM Manual Chain Hoist	107
SS3F2-GM	Single Stage Air Compressor	67
SS3J2-WB	Single Stage Air Compressor	68
SS3J3-WB	Single Stage Air Compressor	68
SS3J5.5GH-WB	Single Stage Air Compressor	68
SS3L3	Single Stage Air Compressor	69
SS5L5	Single Stage Air Compressor	69

**T**

TL10	Task Light	59
------	------------	----

**U**

UP6-5-125	Rotary Screw Air Compressor	73
UP6-5-150	Rotary Screw Air Compressor	73
UP6-5TAS-125	Rotary Screw Air Compressor	74
UP6-5TAS-150	Rotary Screw Air Compressor	74
UP6-7.5-125	Rotary Screw Air Compressor	73
UP6-7.5-150	Rotary Screw Air Compressor	73
UP6-7.5TAS-125	Rotary Screw Air Compressor	74
UP6-7.5TAS-150	Rotary Screw Air Compressor	74
UP6-10-125	Rotary Screw Air Compressor	73
UP6-10-150	Rotary Screw Air Compressor	73
UP6-10TAS-125	Rotary Screw Air Compressor	74
UP6-10TAS-150	Rotary Screw Air Compressor	74
UP6-15c-125	Rotary Screw Air Compressor	73
UP6-15c-150	Rotary Screw Air Compressor	73
UP6-15cTAS-125	Rotary Screw Air Compressor	74
UP6-15cTAS-150	Rotary Screw Air Compressor	74

**V**

VPAD-6	Vacuum Pad 3/8"	40
--------	-----------------	----

**W**

W040	Cordless Impacttools	55
W040P	Cordless Impacttools	55
W040SQ	Cordless Impacttools	55
W150	Cordless Impacttools	55
W150P	Cordless Impacttools	55
W150QC	Cordless Impacttools	55
W175	Cordless Impacttools	55
W175P	Cordless Impacttools	55
W360	Cordless Impacttools	55
W360-2	Cordless Impacttools	55
W360P	Cordless Impacttools	55
WF-14A-007	Spoon Chisel	47
WF-14B-007	Wide Chisel	47
WF-14C-008	Wide Chisel	47
WF-14D-008	Wide Chisel	47

**Numbers**

105-D2	1/4" Square Drive Air Ratchet Wrench	18
--------	--------------------------------------	----

Model Number	Description	Page
105-D3	3/8" Square Drive Air Ratchet Wrench	18
105-L2	1/4" Square Drive Air Ratchet Wrench	18
107XPA	3/8" Square Drive Air Ratchet Wrench	19
109XPA	3/8" Square Drive Air Ratchet Wrench	19
115	Air Hammer	46
115-183	Spring Retainer	47
115K	Air Hammer	46
116	Air Hammer	46
116K	Air Hammer	46
117	Air Hammer	46
117K	Air Hammer	46
121-K6	Air Hammer	46
121/Q	Air Hammer	46
125	Needle and Chisel Scaler	47
125CI	Needle and Chisel Scaler	47
132	Air Hammer	46
211	3/8" Square Drive Air Impactool	7
212	3/8" Square Drive Air Impactool	7
216B	3/8" Square Drive Air Impactool	7
231C	1/2" Square Drive Air Impactool	8
231HA	1/2" Square Drive Air Impactool	8
231HA-2	1/2" Square Drive Air Impactool	8
232TGSL	1/2" Square Drive Air Impactool	9
236	1/2" Square Drive Air Impactool	8
244A	1/2" Square Drive Air Impactool	8
244A-2	1/2" Square Drive Air Impactool	8
259	3/4" Square Drive Air Impactool	11
261	3/4" Square Drive Air Impactool	11
261-3	3/4" Square Drive Air Impactool	11
261-6	3/4" Square Drive Air Impactool	11
271	1" Square Drive Air Impactool	12
280	1" Square Drive Air Impactool	12
280-6	1" Square Drive Air Impactool	12
280-S-6	#5 Spline Drive Air Impactool	12
285B	1" Square Drive Air Impactool	12
285B-6	1" Square Drive Air Impactool	12
285B-S6	#5 Spline Drive Air Impactool	12
290	1" Square Drive Air Impactool	13
290-S	#5 Spline Drive Air Impactool	13
293	1" Square Drive Air Impactool	13
293-S	#5 Spline Drive Air Impactool	13
295A	1" Square Drive Air Impactool	13
301	Air Grinders	29
301-2MK	Surface Conditioning Kit	31
301-3MK	Surface Conditioning Kit	31
301-32MK	Surface Conditioning Kit	31
301-K	Surface Conditioning Kit	31
302A	Air Grinders	29
307A	Air Grinders	29
307-K	Surface Conditioning Kit	31
308A	Air Grinders	29
311A	Air Finishing Tool	37, 40
311A-825-6	Dual Action Backing Pad	40
312A	Air Finishing Tool	36
313A	Air Finishing Tool	37, 40
313A-825-7	Backing Pad	40
314A	Air Finishing Tool	37
315	Air Finishing Tool	36
315-39	Sanding Pad	40
317A	Air Finishing Tool	36

## Index

Model Number	Description	Page
318A	Air Finishing Tool	37
319A	Air Finishing Tool	37
325B	Air Cutting Tool	32
326	Air Grinder	30
327	Air Finishing Tool	36
327LS	Air Finishing Tool	36
328B	Air Finishing Tool	37
328B-825-8	Dual-Action Backing Pad	40
345MAX	Air Grinders	30
371	1/4" Chuck Screwdriver	43
429	Air Cutting Tool	32
728-99-KC5	Replacement Chuck/Chuck Key	44
728-99-KC8	Replacement Chuck/Chuck Key	44
1077XPA	1/2" Square Drive Air Ratchet Wrench	19
1099XPA	1/2" Square Drive Air Ratchet Wrench	19
1105MAX-D2	1/4" Square Drive Air Ratchet Wrench	18
1105MAX-D3	3/8" Square Drive Air Ratchet Wrench	18
1207MAX-D3	3/8" Square Drive Air Ratchet Wrench	19
1207MAX-D4	1/2" Square Drive Air Ratchet Wrench	19
2015MAX	3/8" Square Drive Air Impactool	7
2025MAX	1/2" Square Drive Air Impactool	9
2101K	1/4" Mini Impactool Kit	7, 51
2101XP	1/4" Mini Impactool	7, 49
2101XP-QC	1/4" Mini Impactool	7, 49
2102XP	3/8" Mini Impactool	7, 49
2115QTiMAX	3/8" Square Drive Mini Impactool	7
2115TiMAX	3/8" Square Drive Mini Impactool	7
2125QTiMAX	1/2" Square Drive Air Impactool	9
2130	1/2" Square Drive Air Impactool	9
2130-2	1/2" Square Drive Air Impactool	9
2135QTi-2MAX	1/2" Square Drive Air Impactool	10
2135QTiMAX	1/2" Square Drive Air Impactool	10
2135Ti-2MAX	1/2" Square Drive Air Impactool	10
2135TiMAX	1/2" Square Drive Air Impactool	10
2141	3/4" Square Drive Air Impactool	11
2161XP	3/4" Square Drive Air Impactool	11
2161XP-6	3/4" Square Drive Air Impactool	11
2171XP	1" Square Drive Air Impactool	13
2190DTi-6	1" Square Drive Air Impactool	13
2190Ti	1" Square Drive Air Impactool	13
2190Ti-6	1" Square Drive Air Impactool	13
2340L5-V	Two Stage Air Compressor	70
2340N5-V	Two Stage Air Compressor	70
2475N5-P	Two Stage Air Compressor	72
2475N5-V	Two Stage Air Compressor	70
2475N7.5-P	Two Stage Air Compressor	72
2475N7.5-V	Two Stage Air Compressor	70
2545E10-P	Two Stage Air Compressor	72
2545E10-V	Two Stage Air Compressor	70
2545E10-VP	Two Stage Air Compressor	71
2545EK10-V	Two Stage Air Compressor	70
2545K10-P	Two Stage Air Compressor	72
2545K10-VP	Two Stage Air Compressor	71
2545N7.5-PS	Electric Start-up Kit	78
3102	Air Grinder	30
3102K	Surface Conditioning Kit	31
3103K	Mini Surface Prep Sander Kit	51
3103XP	Mini Surface Prep Grinder	30, 50
3108	Air Grinder	30
3108K	Surface Conditioning Kit	31

Model Number	Description	Page
3128K	Mini Random Orbital Sander Kit	51
3128XP	Mini Random Orbital Sander	37, 50
3129K	Mini Polisher Kit	37, 51
3129XP	Mini Polisher	37, 50
3445MAX	Air Grinder	30
4102K	Surface Conditioning Kit	31
4151	Air Finishing Tool	38
4151-2	Air Finishing Tool	38
4151-5	Air Finishing Tool	38
4151-A809A-25	Vacuum Adapter	40
4151-HL	Air Finishing Tool	38
4151JV	Jet-Vac Conversion Kit	39, 40
4152	Air Finishing Tool	38
4152-HL	Air Finishing Tool	38
4429	Air Cutting Tool	32
6120A	Dual-Action Backing Pad	40
6121A	Dual-Action Backing Pad	40
6122A	Dual-Action Backing Pad	40
6123A	Dual-Action Backing Pad	40
6130A	Backing Pad	40
6135A	Polishing Pad	40
6332	Low-Pressure Hose Reel	87
6358	Low-Pressure Hose Reel	87
6786	Non-drip Nozzle/hose	89
7100	Electric Start-up Kit	78
7100E10-PS	Electric Start-up Kit	78
7100E15-P	Two Stage Air Compressor	72
7100E15-V	Two Stage Air Compressor	70
7802A	3/8" Chuck Drill	42
7802RA	3/8" Chuck Drill	42
7802RAKC	3/8" Chuck Drill	42
7802SA	Air Cutting Tool	32
7803-99	Replacement Chuck/Chuck Key	44
7803A	1/2" Chuck Drill	42
7803RA	1/2" Chuck Drill	42
7803RAKC	1/2" Chuck Drill	42
7804K	1/4" Mini Drill/Driver	51
7804XP	1/4" Mini Drill/Driver	43, 50
7807R	3/8" Chuck - Right Angle Drill	43
9500	Replacement Chisels	47
9505	Replacement Chisels	47
9512	Replacement Chisels	47
30131-2	Service Kit	40
44548	Spanner Wrench	40
48266-1	Shroud	40
48878	Shroud	40
49094-1	3/8" Non-Vacuum Pad	40
49096-1	3/8" Vacuum Pad	40
49694	3/8" Vacuum Pad	40
49877-1	3/8" Non-Vacuum Pad	40
49879-1	3/8" Non-Vacuum Pad	40
49987	Jet-Vac Vacuum Bag	40
49988	Jet-Vac Vacuum Bag	40
60798	Non-drip Nozzle/hose	89
66605J-322	Diaphragm Pump	86
66605J-344	Diaphragm Pump	85
66605J-388	Diaphragm Pump	86
611016	Hand-operated Pump	91
611170	Hand-operated Pump	91
612041-1	Piston Pump	84

## Index

Model Number	Description	Page
612041-3	Piston Pump	84
612042-1	Piston Pump	84
612999-3	Specialty Application Pump	86
612999-4	Specialty Application Pump	86
612999-5	Specialty Application Pump	86
612999-6	Specialty Application Pump	86
613201-2-C	Specialty Application Pump	86
629212	Non-drip Nozzle/hose	89
629226	Non-drip Nozzle/hose	89
629245-1	Non-drip Nozzle/hose	89
629245-2	Non-drip Nozzle/hose	89
629516	Non-drip Nozzle/hose	89
629521	Non-drip Nozzle/hose	89
629742	Grease Control Handle	90
635129	Non-metered Fluid Control Handle	88
635190-1	Metered Fluid Control Handle	88
635190-2	Metered Fluid Control Handle	88
635190-3	Metered Fluid Control Handle	88
635193	Non-metered Fluid Control Handle	88
635360-2	Metered Fluid Control Handle	89
635360-3	Metered Fluid Control Handle	89
635360-22	Metered Fluid Control Handle	89
635360-33	Metered Fluid Control Handle	89
635364	Metered Fluid Control Handle	89
635365	Metered Fluid Control Handle	89
635367	Metered Fluid Control Handle	89
635390-1	Metered Fluid Control Handle	88
635390-2	Metered Fluid Control Handle	88
635390-3	Metered Fluid Control Handle	88
635390-10	Metered Fluid Control Handle	88
635390-11	Metered Fluid Control Handle	88
635390-20	Metered Fluid Control Handle	88
635390-22	Metered Fluid Control Handle	88
635390-30	Metered Fluid Control Handle	88
635390-33	Metered Fluid Control Handle	88
635391-1	Metered Fluid Control Handle	88
635391-11	Metered Fluid Control Handle	88
635392	Non-metered Fluid Control Handle	88
635395-2	Non-metered Fluid Control Handle	88
635399	Non-metered Fluid Control Handle	88
636101	Grease Control Handle	90
636103	Grease Control Handle	90
636111	Grease Control Handle	90
650715-C	Specialty Application Pump	86
650717-C	Diaphragm Pump	86
650718-C	Diaphragm Pump	86
650719-C	Diaphragm Pump	86
662409	Piston Pump	84
662410-B	Piston Pump	84
662420-B	Piston Pump	84
666100-3C9-C	Diaphragm Pump	86
666100-322-C	Diaphragm Pump	86
666100-344-C	Diaphragm Pump	86
666100-362-C	Diaphragm Pump	86
666150-362-C	Diaphragm Pump	86
666250-9C9-C	Diaphragm Pump	86
950011	Replacement Chisels	47
950012	Replacement Chisels	47
950013	Replacement Chisels	47
950014	Replacement Chisels	47

Model Number	Description	Page
950015	Replacement Chisels	47
950016	Replacement Chisels	47
950017	Replacement Chisels	47
950018	Replacement Chisels	47
950019	Replacement Chisels	47



# Index

<b>Model Number</b>	<b>Description</b>	<b>Page</b>	<b>Model Number</b>	<b>Description</b>	<b>Page</b>
-------------------------	--------------------	-------------	-------------------------	--------------------	-------------

## Why certified service?

- Genuine parts and lubricants
- Factory certified technicians
- Tested to OEM specifications
- Factory repair warranty

***... Peace of mind!***

For service and repair visit, us at  
**[irtools.com/locator](http://irtools.com/locator)**